

SINGLE

Technical Data Book

Big duct /Big Ceiling for Argentina (R410A, 50Hz, HP)



Model : IDU : AC****N***H/AR

ODU : AC****X***H/AR

History

Version	Modification	Date	Remark
Ver 1.0	Release SINGLE Big duct /Big Ceiling for Argentina (R410A, 50Hz, HP)	17.02.15	-

Nomenclature

Indoor Units

Model Names

AC	200	K	N	H	P	K	H	/	AR
(1)	(2)	(3)	(4)	(5)	(6)	(7)	(8)		Buyer

(1) Classification

AC	SINGLE
AM	VRF

(2) Capacity

x 1/10 kW (3 digits)

(3) Version

F	2013
H	2014
J	2015
K	2016

(4) Product Type

N	Indoor Unit
X	Outdoor Unit

(5) Product Notation

1	1Way Cassette
2	2Way Cassette
N	4Way Cassette (600 x 600)
4	4Way Cassette
L	LSP Duct (Slim Duct)
M	MSP Duct
H	HSP Duct
C	Ceiling
T	Neo Forte
E	OAP Duct

(6) Feature

D	DELUXE
F	FLAGSHIP
P	Premium
G(EHS)	Cascade (EEV)

(7) Rating Voltage

C	1Ø, 208~230V, 60Hz
E	1Ø, 220~240V, 50Hz
G	3Ø, 380~415V, 50Hz
K	1Ø, 220~240V, 50/60Hz
N	3Ø, 380~415V, 50/60Hz

(8) Mode

C	Cooling Only(R410A)
H	Heat Pump(R410A)
D	Cooling Only(R22)
E	Heat Pump(R22)

Nomenclature

Outdoor Units

Model Names

AC	200	K	X	A	P	N	H	/	AR
(1)	(2)	(3)	(4)	(5)	(6)	(7)	(8)		Buyer

(1) Classification

AC	SINGLE
AM	VRF

(5) Feature1

A	Inv+Side+General Temp
B	Non Inv+Side+General Temp

(2) Capacity

x 1/10 kW (3 digits)

(6) Feature2

D	Deluxe
F	Flagship
P	Premium
S	Standard

(3) Version

F	2013
H	2014
J	2015
K	2016

(7) Rating Voltage

E	1Ø, 220~240V, 50Hz
G	3Ø, 380~415V, 50Hz
K	1Ø, 220~240V, 50/60Hz
N	3Ø, 380~415V, 50/60Hz

(4) Product Type

N	Indoor Unit
X	Outdoor Unit

(8) Mode

C	Cooling Only(R410A)
H	Heat Pump(R410A)
D	Cooling Only(R22)
E	Heat Pump(R22)

Big Duct

1 Specifications _____

2 Capacity table _____

3 Dimensional drawing _____

4 Electrical wiring diagram _____

5 Sound pressure level _____

6 Sound power level _____

7 Recommended operation range _____

8 Cycle diagram _____

9 Capacity correction _____

1 Specifications

Big Duct

Type				HSP Duct	HSP Duct		
Model Name	Indoor Unit			AC180JNHPKH/AR	AC200KNHPKH/AR		
	Outdoor Unit			AC180JXAPNH/AR	AC200KXAPNH/AR		
System	Mode				Heat Pump	Heat Pump	
	Capacity	Cooling(Min/Std/Max)		kW	6.00 / 18.00 / 20.00	7.50 / 20.00 / 23.00	
				Btu/h	20,500 / 61,400 / 68,200	25,600 / 68,200 / 78,500	
		Heating(Min/Std/Max)		kW	4.80 / 20.00 / 22.50	8.50 / 23.00 / 25.00	
				Btu/h	16,400 / 68,200 / 76,800	29,000 / 78,500 / 85,300	
	Power	Power Input (Nominal)	Cooling(Min/Std/Max)	kW	1.30 / 5.45 / 7.30	2.10 / 6.45 / 8.00	
			Heating(Min/Std/Max)	kW	1.20 / 5.54 / 7.60	2.10 / 6.66 / 9.80	
		Current Input (Nominal)	Cooling(Min/Std/Max)	A	2.30 / 8.40 / 16.10	3.80 / 10.00 / 12.30	
			Heating(Min/Std/Max)	A	2.20 / 8.60 / 16.10	3.80 / 10.30 / 16.00	
		MCA			A	18.60 (MCA)	25.00 (MCA)
		MFA			A	20.46	31.25
	Energy Efficiency	EER (Nominal Cooling)		-	3.30	3.10	
		COP (Nominal Heating)		-	3.61	3.45	
		Energy Grade		-	-	-	
	Piping Connections	Liquid Pipe		Ø, mm	9.52	9.52	
				Ø, inch	3/8"	3/8"	
		Gas Pipe		Ø, mm	19.05	19.05	
				Ø, inch	3/4"	3/4"	
		Installation Limitation	Max. Length	m	75	75	
			Max. Height	m	30	30	
Field Wiring	Power Source Wire		Ø, mm	-	-		
	Transmission Cable		Ø, mm	-	-		
Refrigerant	Type		-	R410A	R410A		
	Control Method		-	-	-		
	Factory Charging		kg / tCO2e	4.60 / 9.60	6.60 / 13.78		
Indoor Unit	Power Supply			Ø, #, V, Hz	1,2,220-240,50	1,2,220-240,50	
	Fan	Type		-	Sirocco Fan	Sirocco Fan	
		Motor	Output	W	630	630	
		Air Flow Rate	High/Mid/Low	CMM	71.00 / 60.00 / 50.00	72.00 / 62.00 / 48.00	
				l/s	1,183.33 / 1,000.00 / 833.33	1,200.00 / 1,000.00 / 800.00	
		External Static Pressure	Min/Std/Max	mmAq	5.00 / 6.12 / 20.00	5.00 / 7.34 / 20.00	
	Pa			49.00 / 60.00 / 196.00	49.00 / 71.95 / 196.00		
	Drain	Drain Pipe		Ø,mm	VP25 (OD 32,ID 25)	VP25 (OD 32,ID 25)	
		Pressure	High/Mid/Low		43 / 39 / 35	44 / 40 / 36	
	Sound	Power	Cooling	dB(A)	69	70	
	External Dimension	Net Weight		kg	82.50	82.50	
		Shipping Weight		kg	92.00	92.00	
		Net Dimensions (WxHxD)		mm	1,350 x 450 x 910	1,350 x 450 x 910	
		Shipping Dimensions (WxHxD)		mm	1,612 x 519 x 984	1,612 x 519 x 984	
	Panel Size	Panel model		-	-	-	
		Panel Net Weight		kg	-	-	
		Shipping Weight		kg	-	-	
		Net Dimensions (WxHxD)		mm	-	-	
	Additional Accessories	Shipping Dimensions (WxHxD)		mm	-	-	
Drain pump		External	-	MDP-G075SP	MDP-G075SP		
		Internal	-	MDP-G075SQ	MDP-G075SQ		
Air Filter		-	-	-			
Outdoor Unit	Power Supply			Ø, #, V, Hz	3,4,380-415,50	3,4,380-415,50	
	Compressor	Type		-	Twin BLDC Rotary	BLDC Scroll	
		Model		-	UG5T520FUBJX	DS-GB066FAVB	
		Output		kW	4.78	6.39	
	Oil	Type		-	PVE	PVE	
	Fan	Air Flow Rate	Cooling	CMM	110.00	200.00	
				l/s	1,833.33	3,333.33	
	Sound	Pressure	Cooling/Heating	dB(A)	55 / 57	58 / 60	
		Power	Cooling	dB(A)	76	75	
	External Dimension	Net Weight		kg	107.50	154.00	
		Shipping Weight		kg	117.50	167.00	
		Net Dimensions (WxHxD)		mm	940 x 1,420 x 330	940 x 1,630 x 460	
		Shipping Dimensions (WxHxD)		mm	995 x 1,598 x 426	1,020 x 1,820 x 575	
	Operating Temp. Range	Cooling		°C	-15.0 ~ 50.0	-20.0 ~ 50.0	
		Heating		°C	-20.0 ~ 24.0	-20.0 ~ 24.0	

- All figures comply with EN14511

- Nominal cooling capacities are based on;

Indoor temperature : 27°C DB, 19°C WB / Outdoor temperature : 35°C DB, Refrigerant piping : 5m , Level differences : 0m

- Nominal heating capacities are based on;

Indoor temperature : 20°C DB, 15°C WB / Outdoor temperature : 7°C DB, 6°C WB, Refrigerant piping : 5m, Level differences : 0m

- Sound level was acquired in an anechoic room. Thus actual noise level may be different depending on the installation conditions.

- Specifications may be subject to change without prior notice.

- These products contain R410A(GWP=2,088) which is fluorinated greenhouse gas.

- If indoor unit is located in a higher position than outdoor unit, please refer to the ()* value of Installation Height Limitation.

1 Specifications

Big Duct

Type				HSP Duct		
Model Name	Indoor Unit			AC250KNHPKH/AR		
	Outdoor Unit			AC250KXAPNH/AR		
System	Mode			Heat Pump		
	Capacity	Cooling(Min/Std/Max)		kW	9.00 / 25.00 / 28.50	
				Btu/h	30,700 / 85,300 / 97,200	
		Heating(Min/Std/Max)		kW	10.00 / 27.00 / 32.00	
				Btu/h	34,100 / 92,100 / 109,200	
	Power	Power Input (Nominal)	Cooling(Min/Std/Max)	kW	2.60 / 9.58 / 12.00	
			Heating(Min/Std/Max)		2.50 / 8.33 / 13.50	
		Current Input (Nominal)	Cooling(Min/Std/Max)	A	4.70 / 14.90 / 18.40	
			Heating(Min/Std/Max)		4.50 / 12.90 / 22.00	
		MCA		A	25.00	
		MFA		A	31.25	
	Energy Efficiency	EER (Nominal Cooling)		-	2.61	
		COP (Nominal Heating)		-	3.24	
		Energy Grade		-	-	
	Piping Connections	Liquid Pipe		Ø, mm	9.52	
				Ø, inch	3/8"	
		Gas Pipe		Ø, mm	22.22	
				Ø, inch	7/8"	
		Installation Limitation	Max. Length	m	75	
			Max. Height	m	30	
	Field Wiring	Power Source Wire		Ø, mm	-	
		Transmission Cable		Ø, mm	-	
	Refrigerant	Type		-	R410A	
		Control Method		-	-	
Factory Charging		kg / tCO2e	6.60 / 13.78			
Indoor Unit	Power Supply			Ø, #, V, Hz	1,2,220-240,50	
	Fan	Type		-	Sirocco Fan	
		Motor	Output		W	630
			Air Flow Rate		High/Mid/Low	CMM
		External Static Pressure	Min/Std/Max		l/s	1,333.33 / 1,066.67 / 850.00
			mmAq	5.00 / 7.34 / 20.00		
	Drain	Drain Pipe		Ø,mm	VP25 (OD 32,ID 25)	
		Sound	Pressure	High/Mid/Low		47 / 42 / 37
	External Dimension		Power	Cooling		72
		Net Weight		kg	82.50	
	Shipping Weight		kg	92.00		
	Net Dimensions (WxHxD)		mm	1,350 x 450 x 910		
	Shipping Dimensions (WxHxD)		mm	1,612 x 519 x 984		
	Panel Size	Panel model		-	-	
		Panel Net Weight		kg	-	
		Shipping Weight		kg	-	
		Net Dimensions (WxHxD)		mm	-	
	Additional Accessories	Shipping Dimensions (WxHxD)		mm	-	
		Drain pump	External	-	MDP-G075SP	
	Internal		-	MDP-G075SQ		
	Air Filter		-	-		
	Outdoor Unit	Power Supply			Ø, #, V, Hz	3,4,380-415,50
		Compressor	Type		-	BLDC Scroll
			Model		-	DS-GB066FAVB
Output			kW	6.39		
Oil			Type		-	PVE
		Fan	Air Flow Rate	Cooling	CMM	200.00
			l/s	3,333.33		
Sound		Pressure	Cooling/Heating		59 / 61	
		Power	Cooling		77	
External Dimension		Net Weight		kg	154.00	
		Shipping Weight		kg	167.00	
		Net Dimensions (WxHxD)		mm	940 x 1,630 x 460	
		Shipping Dimensions (WxHxD)		mm	1,020 x 1,820 x 575	
Operating Temp. Range		Cooling		°C	-20.0 ~ 50.0	
		Heating		°C	-20.0 ~ 24.0	

* Specifications may be subject to change without prior notice.

- Nominal cooling capacities are based on;
 - Indoor temperature : 27°C DB, 19°C WB
 - Outdoor temperature : 35°C DB, 24°C WB, Equivalent refrigerant piping : 5m, Level differences : 0m
- Nominal heating capacities are based on;
 - Indoor temperature : 20°C DB, 15°C WB
 - Outdoor temperature : 7°C DB, 6°C WB, Equivalent refrigerant piping : 5m, Level differences : 0m
- Sound pressure was acquired in an anechoic room. Thus actual noise level may be different depending on the installation conditions.
- These products contain R410A(GWP=2,088) which is fluorinated greenhouse gas.

2 Capacity table

AC180JNHPKH/AR + AC180JXAPNH/AR

Cooling

TC(Total Capacity), SHC(Sensible Heat Capacity), PI(Power Input)

Outdoor temperature (°C, DB)	Indoor temperature (°C, WB)																	
	14.0			16.0			18.0			19.0			22.0			24.0		
	TC	SHC	PI	TC	SHC	PI	TC	SHC	PI	TC	SHC	PI	TC	SHC	PI	TC	SHC	PI
-15.0	19.91	15.93	4.15	20.40	16.32	4.26	20.91	16.72	4.36	21.42	17.14	4.47	21.93	17.55	4.58	22.46	17.97	4.69
21.0	20.75	16.60	4.31	21.26	17.01	4.41	21.78	17.43	4.52	22.32	17.86	4.63	22.86	18.28	4.74	23.40	18.72	4.86
35.0	16.73	13.39	5.07	17.15	13.72	5.19	17.57	14.05	5.32	18.00	14.40	5.45	18.43	14.75	5.58	18.87	15.10	5.71
46.0	13.22	10.58	5.83	13.55	10.84	5.97	13.88	11.10	6.12	14.22	11.38	6.27	14.56	11.65	6.42	14.91	11.93	6.57
52.0	10.86	8.69	5.32	11.13	8.90	5.45	11.40	9.12	5.59	11.68	9.35	5.72	11.96	9.57	7.10	12.25	9.80	7.27

Heating

TC : Total Capacity, PI: Power Input

Outdoor temperature (°C, DB)	Indoor temperature (°C, DB)											
	16.0		18.0		20.0		21.0		22.0		24.0	
	TC	PI	TC	PI	TC	PI	TC	PI	TC	PI	TC	PI
-20.0	14.08	7.06	13.94	6.99	13.80	6.93	13.66	6.86	13.53	6.79	13.39	6.72
-10.0	19.18	8.19	18.99	8.11	18.80	8.03	18.61	7.95	18.43	7.87	18.24	7.79
7.0	20.40	5.65	20.20	5.60	20.00	5.54	19.80	5.48	19.60	5.43	19.41	5.38
24.0	27.34	6.50	27.07	6.43	26.80	6.37	26.53	6.31	26.27	6.24	26.00	6.18

AC200KNHPKH/AR + AC200KXAPNH/AR

Cooling

TC(Total Capacity), SHC(Sensible Heat Capacity), PI(Power Input)

Outdoor Air Temp. (DB)	Indoor temperature (°C)																				
	20 (DB)			23 (DB)			26 (DB)			27 (DB)			28 (DB)			30 (DB)			32 (DB)		
	14 (WB)			16 (WB)			18 (WB)			19 (WB)			20 (WB)			22 (WB)			24 (WB)		
-20.0	19.90	16.60	4.52	20.90	17.10	4.61	21.80	17.70	4.71	22.50	18.20	4.80	22.90	18.00	4.85	24.10	17.90	4.90	25.30	17.50	5.00
21.0	18.60	15.50	4.86	19.60	16.00	4.96	20.40	16.50	5.06	21.00	17.00	5.16	21.40	16.80	5.21	22.50	16.60	5.26	23.60	16.30	5.37
35.0	17.70	14.70	6.07	18.60	15.20	6.19	19.40	15.70	6.32	20.00	16.20	6.45	20.40	16.00	6.51	21.40	15.80	6.58	22.50	15.50	6.71
46.0	14.00	12.70	6.10	14.70	13.10	6.23	15.30	13.50	6.35	15.80	13.90	6.48	16.10	13.80	6.55	16.90	13.60	6.61	17.80	13.40	6.74
50.0	11.90	11.30	6.12	12.60	11.70	6.24	13.10	12.00	6.37	13.50	12.40	6.50	13.80	12.30	6.57	14.50	12.20	6.63	15.20	11.90	6.76

Heating

TC : Total Capacity, PI: Power Input

Outdoor Air Temp. (DB)	Indoor temperature (°C)											
	16 (DB)		18 (DB)		20 (DB)		21 (DB)		22 (DB)		24 (DB)	
	TC(kW)	PI(kW)	TC(kW)	PI(kW)	TC(kW)	PI(kW)	TC(kW)	PI(kW)	TC(kW)	PI(kW)	TC(kW)	PI(kW)
-20.0	19.54	8.31	19.41	8.44	19.29	8.61	19.22	8.62	19.16	8.71	19.03	8.77
-20.0	20.30	8.73	20.10	8.87	20.00	9.00	19.90	9.07	19.90	9.14	19.70	9.27
-10.0	21.70	7.65	21.60	7.77	21.40	7.89	21.40	7.94	21.30	8.00	21.20	8.12
0.0	22.40	7.11	22.30	7.22	22.10	7.33	22.10	7.38	22.00	7.44	21.90	7.55
7.0	23.30	6.46	23.20	6.56	23.00	6.66	22.90	6.71	22.90	6.76	22.70	6.86
24.0	28.20	5.53	28.00	5.61	27.80	5.70	27.70	5.74	27.60	5.79	27.40	5.87

AC250KNHPKH/AR + AC250KXAPNH/AR

Cooling

TC(Total Capacity), SHC(Sensible Heat Capacity), PI(Power Input)

Outdoor Air Temp. (DB)	Indoor temperature (°C)																				
	20 (DB)			23 (DB)			26 (DB)			27 (DB)			28 (DB)			30 (DB)			32 (DB)		
	14 (WB)			16 (WB)			18 (WB)			19 (WB)			20 (WB)			22 (WB)			24 (WB)		
-20.0	24.90	19.40	6.72	26.20	20.00	6.85	27.30	20.60	6.99	28.10	21.20	7.14	28.70	21.00	7.21	30.10	20.80	7.28	31.60	20.40	7.42
21.0	23.20	18.10	7.21	24.40	18.60	7.36	25.50	19.20	7.51	26.30	19.80	7.66	26.80	19.60	7.74	28.10	19.40	7.82	29.50	19.00	7.97
35.0	22.10	17.20	9.02	23.30	17.80	9.20	24.30	18.30	9.39	25.00	18.90	9.58	25.50	18.70	9.68	26.80	18.50	9.77	28.10	18.10	9.97
46.0	14.70	13.60	7.99	15.50	14.10	8.16	16.10	14.50	8.32	16.60	14.90	8.49	17.00	14.80	8.58	17.80	14.60	8.66	18.70	14.40	8.84
50.0	10.70	10.80	7.44	11.20	11.10	7.59	11.40	11.40	7.74	12.10	11.80	7.90	12.30	11.70	7.98	12.90	11.60	8.06	13.60	11.30	8.22

Heating

TC : Total Capacity PI: Power Input

Outdoor Air Temp. (DB)	Indoor temperature (°C)											
	16 (DB)		18 (DB)		20 (DB)		21 (DB)		22 (DB)		24 (DB)	
	TC(kW)	PI(kW)	TC(kW)	PI(kW)	TC(kW)	PI(kW)	TC(kW)	PI(kW)	TC(kW)	PI(kW)	TC(kW)	PI(kW)
-20.0	19.94	9.15	19.76	9.50	19.57	9.93	19.48	10.09	19.39	10.31	19.20	10.67
-20.0	21.40	9.91	21.20	10.34	21.00	10.77	20.90	10.98	20.80	11.20	20.60	11.63
-10.0	24.30	8.84	24.10	9.22	23.90	9.61	23.70	9.80	23.60	9.99	23.40	10.38
0.0	25.80	8.30	25.50	8.67	25.30	9.03	25.20	9.21	25.10	9.39	24.80	9.75
7.0	27.50	7.66	27.30	8.00	27.00	8.33	26.90	8.50	26.70	8.66	26.50	9.00
24.0	31.80	6.03	31.50	6.29	31.20	6.55	31.10	6.68	30.90	6.81	30.60	7.07

* Specifications may be subject to change without prior notice for product improvement.

1) Capacities are based on following conditions:

. Cooling mode indoor air temperature (°C, DB/WB) : 20/14, 23/16, 26/18, 27/19, 28/20, 30/22, 32/24 .

. Heating mode outdoor air : 85%RH. However, the condition rated capacity is 7°C DB / 6°C WB.

. Refrigerant piping length : 5m

. Level difference : 0m.

2) In case of Inverter models, the cooling capacity on the capacity table can be higher than nominal capacity as inverter compressors operate with different Hz depending on outdoor and indoor temperatures.

3 Dimensional drawing

Indoor

AC180JNHPKH/AR, AC200KNHPKH/AR, AC250KNHPKH/AR

Units : mm / inches

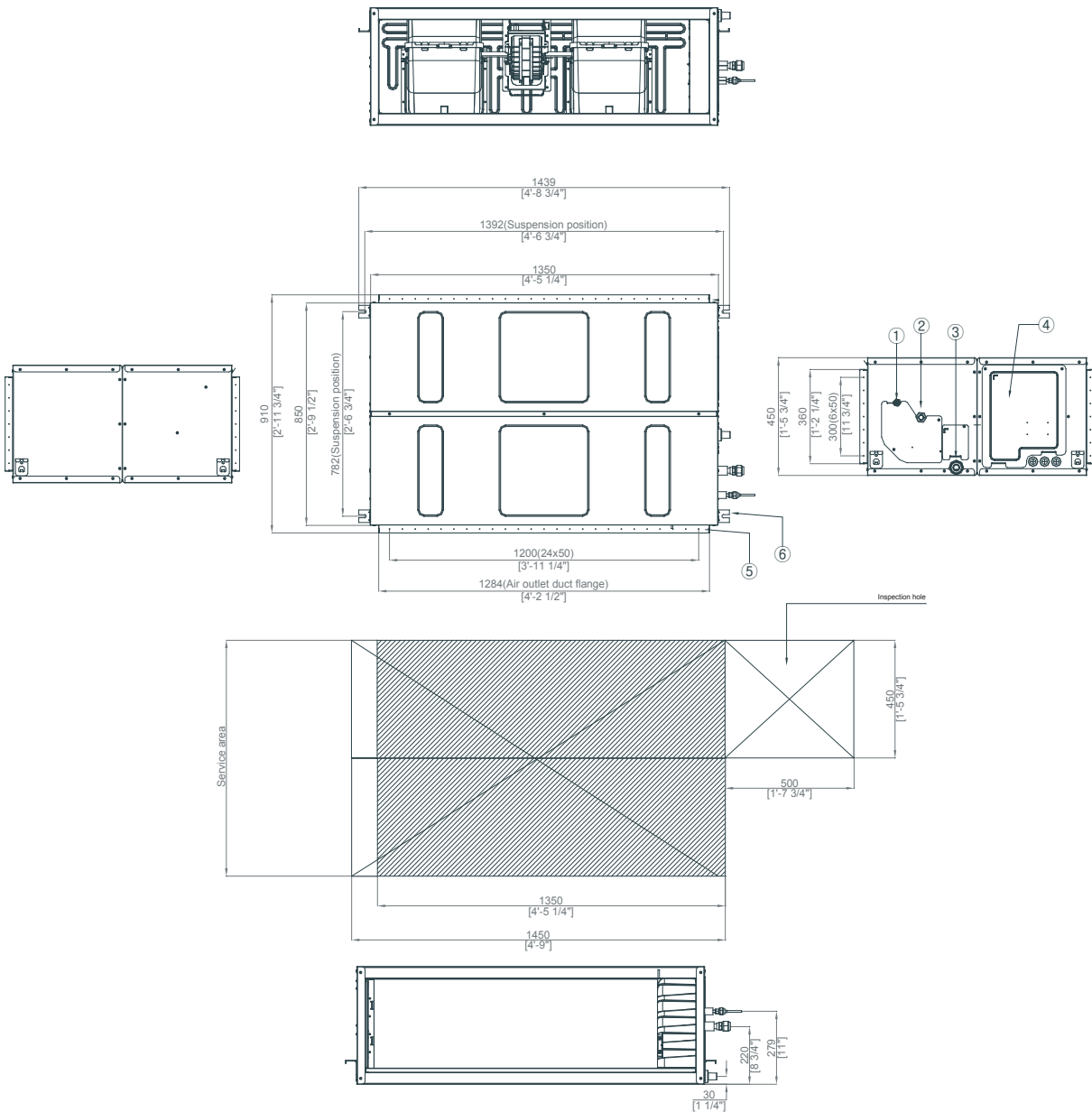

Table of descriptions

1	Liquid pipe connection
2	Gas pipe connection
3	Drain pipe connection
4	Power supply connection
5	Air discharge flange
6	Hook

3 Dimensional drawing

Outdoor

AC180JXAPH/AR

Units : mm / inches

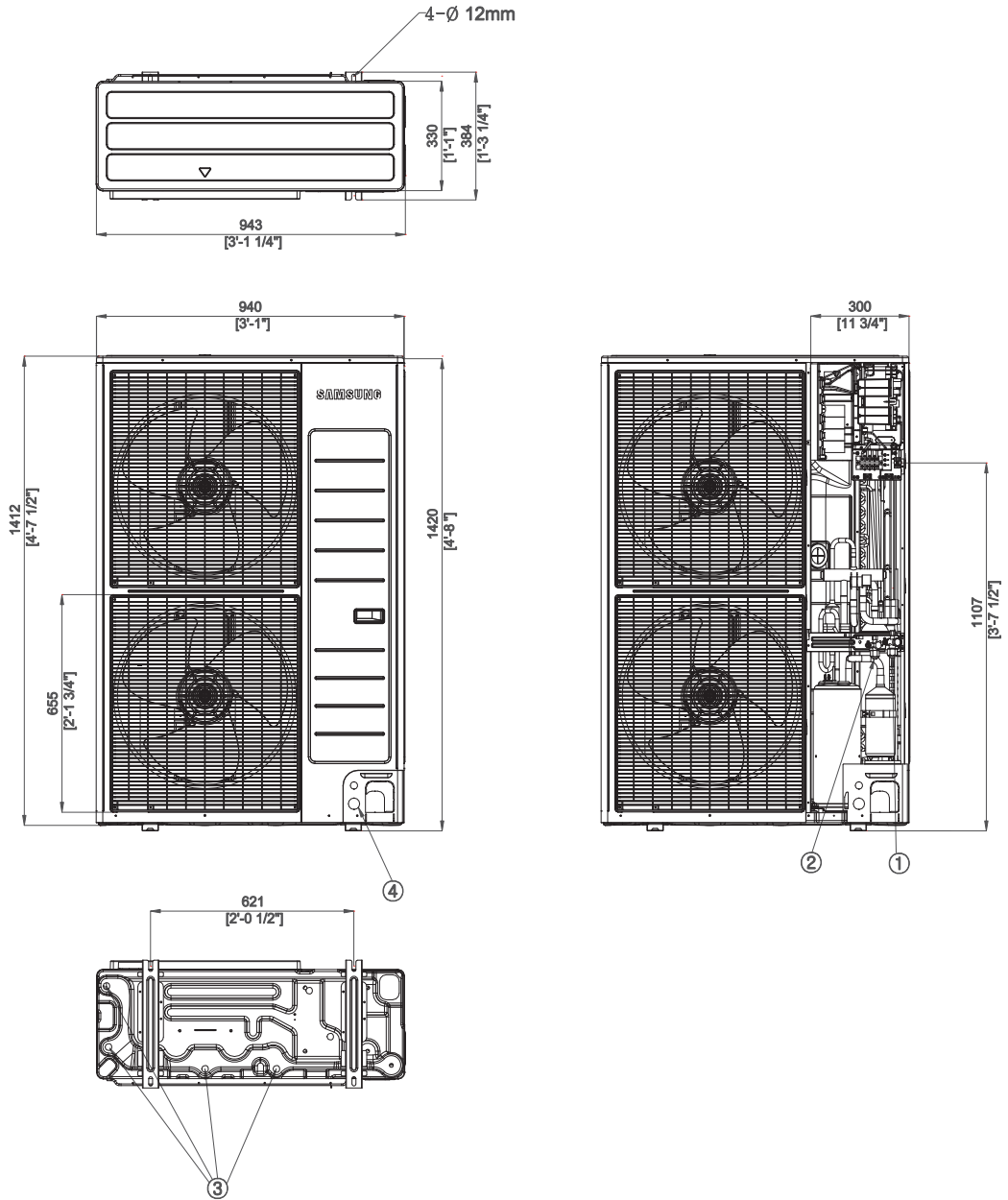

Table of descriptions

1	Refrigerant gas pipe
2	Refrigerant liquid pipe
3	Drain Hole
4	Power & Comm. wiring conduits

3 Dimensional drawing

Outdoor

AC200KXAPNH/AR, AC250KXAPNH/AR

Units : mm / inches

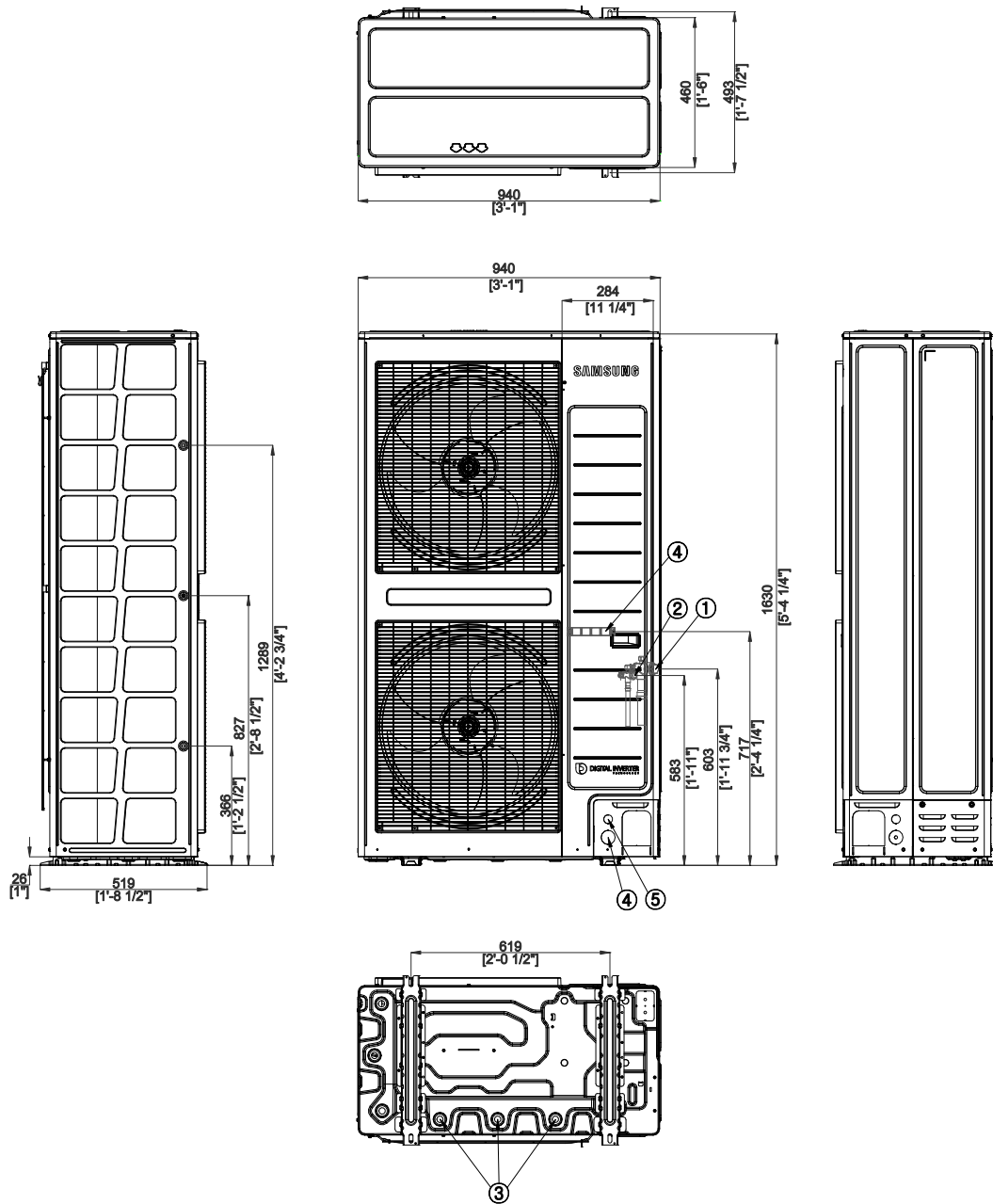

Table of descriptions

1	Refrigerant gas pipe
2	Refrigerant liquid pipe
3	Drain Hole
4	Power wiring conduits
5	Communication wiring conduits

4 Electrical wiring diagram

Outdoor

AC180JXAPNH/AR

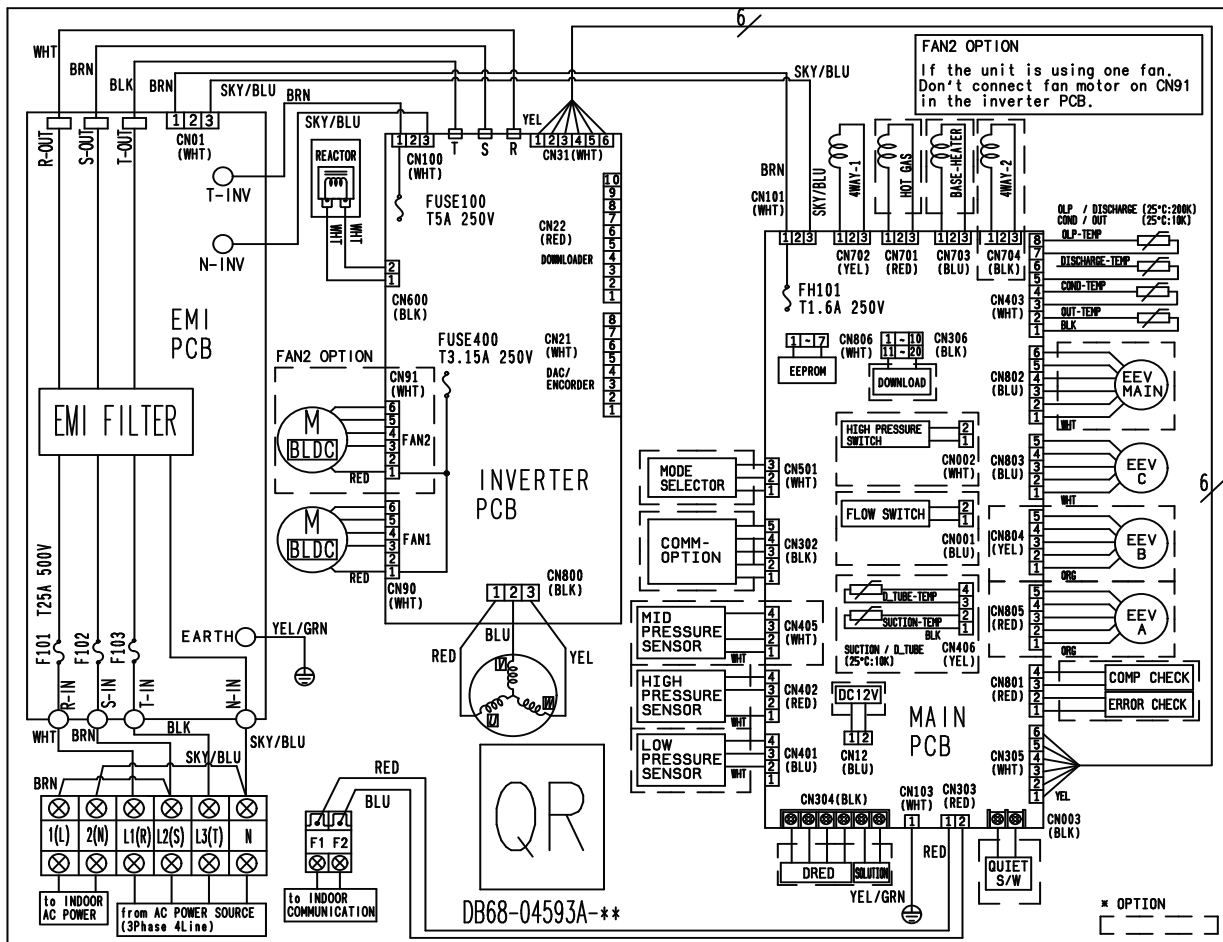

4 Electrical wiring diagram

Outdoor

AC200KXAPH/AR, AC250KXAPH/AR

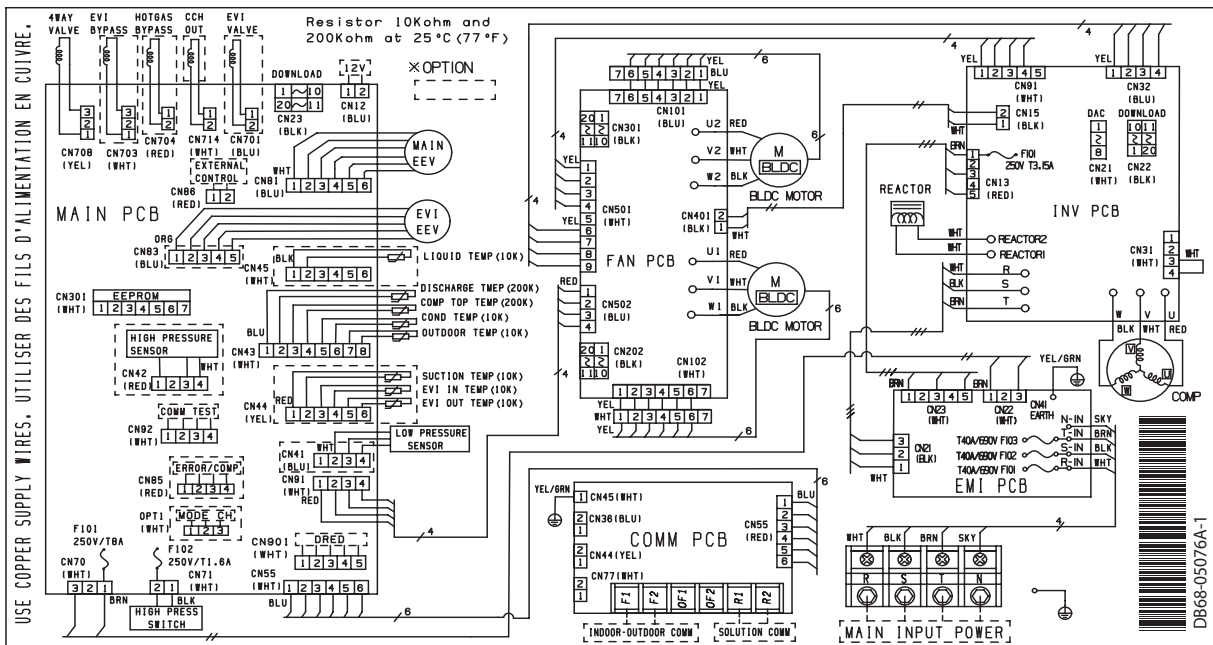

5 Sound pressure level

Indoor

Unit: dB(A)

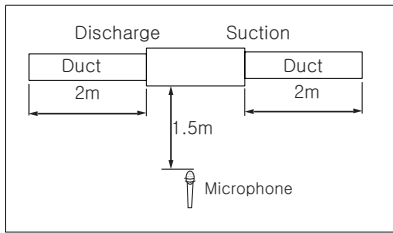

Model	High	Low
AC180JNHPKH/AR (ODU : AC180JXAPNH/AR)	43	35
AC200KNHPKH/AR (ODU : AC200KXAPNH/AR)	44	36
AC250KNHPKH/AR (ODU : AC250KXAPNH/AR)	47	37

Note

* Specifications may be subject to change without prior notice

- 1) These operation values were obtained in an anechoic room.
- 2) Sound pressure level will vary depending on a range of factors such as the construction of the particular room where the equipment is installed.
- 3) Operation sound level may differ depending on operation and ambient conditions.

NC curve

1) AC180JNHPKH/AR (ODU : AC180JXAPNH/AR)

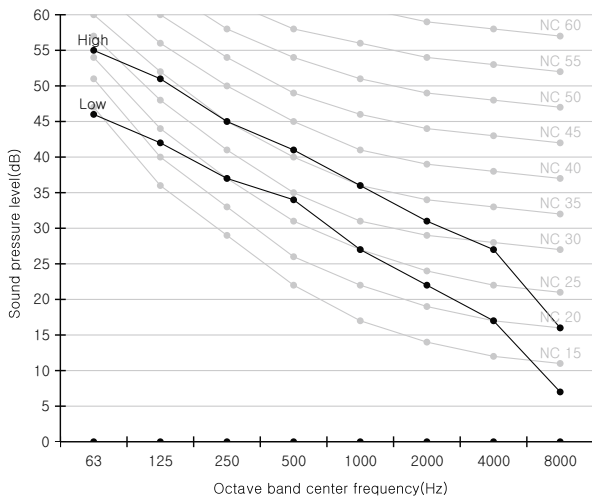

2) AC200KNHPKH/AR (ODU : AC200KXAPNH/AR)

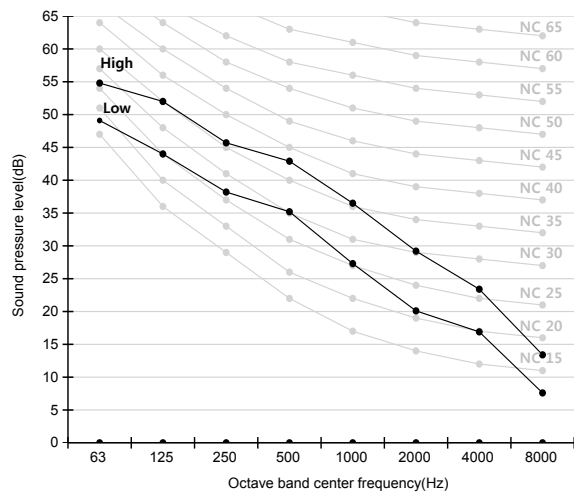

3) AC250KNHPKH/AR (ODU : AC250KXAPNH/AR)

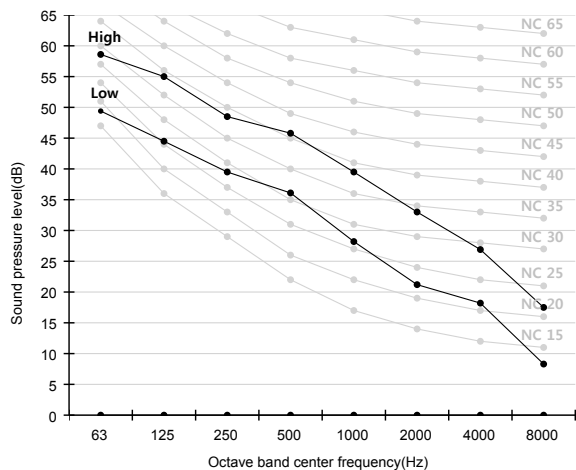

5 Sound pressure level

Outdoor

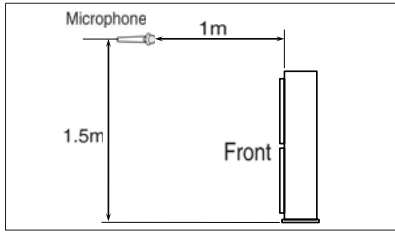

Unit: dB(A)

Model	Cooling	Heating
AC180JXAPNH/AR (IDU : AC180JNHPKH/AR)	55	57
AC200KXAPNH/AR (IDU : AC200KNHPKH/AR)	58	60
AC250KXAPNH/AR (IDU : AC250KNHPKH/AR)	59	61

Note

* Specifications may be subject to change without prior notice

- 1) These operation values were obtained in an anechoic room.
- 2) Sound pressure level will vary depending on a range of factors such as the construction of the particular room where the equipment is installed.
- 3) Operation sound level may differ depending on operation and ambient conditions.

NC curve

1) AC180JXAPNH/AR (IDU : AC180JNHPKH/AR)

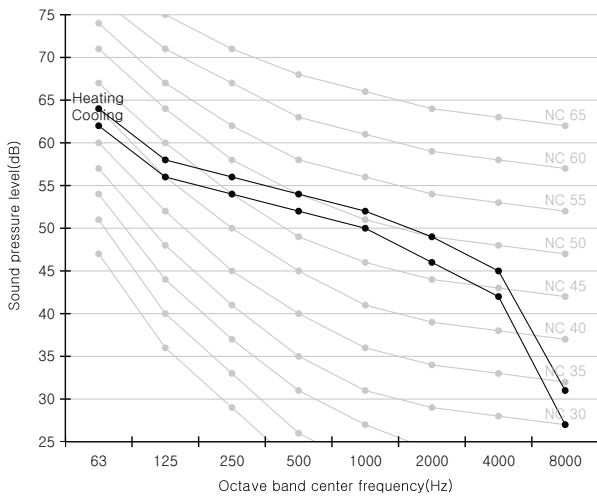

2) AC200KXAPNH/AR (IDU : AC200KNHPKH/AR)

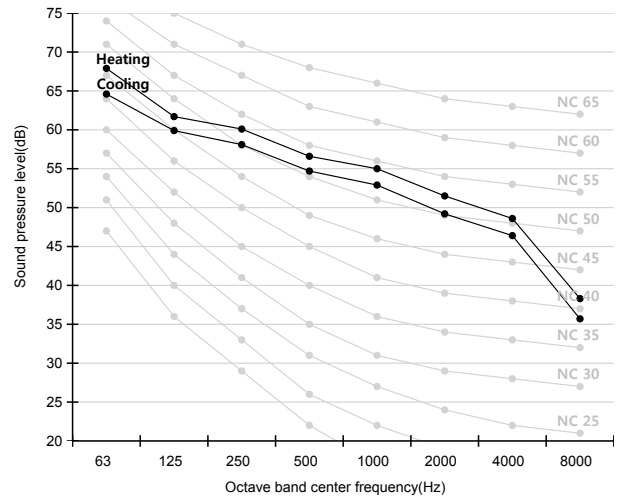

3) AC250KXAPNH/AR (IDU : AC250KNHPKH/AR)

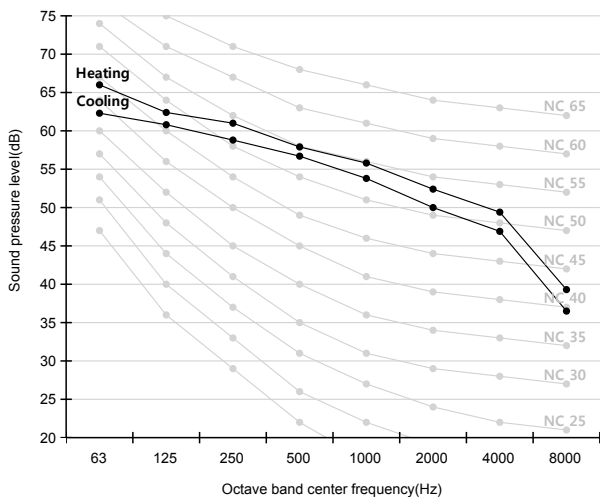

6 Sound Power Level

Indoor

Note

- * Specifications may be subject to change
- 1) dBA = A-weighted sound power level.
- 2) Reference power : 1pW.
- 3) Measured according to ISO 3741.

Unit: dB(A)

Model	Power
AC180JNHPKH/AR (ODU : AC180JXAPNH/AR)	69
AC200KNHPKH/AR (ODU : AC200KXAPNH/AR)	70
AC250KNHPKH/AR (ODU : AC250KXAPNH/AR)	72

1) AC180JNHPKH/AR (ODU : AC180JXAPNH/AR)

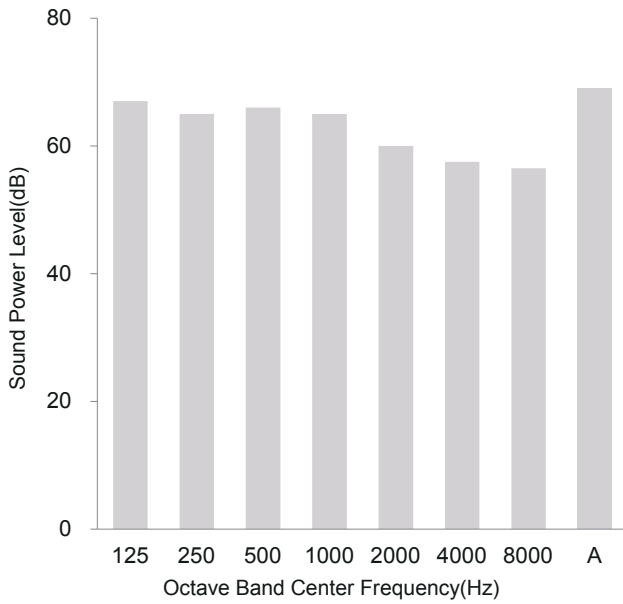

2) AC200KNHPKH/AR (ODU : AC200KXAPNH/AR)

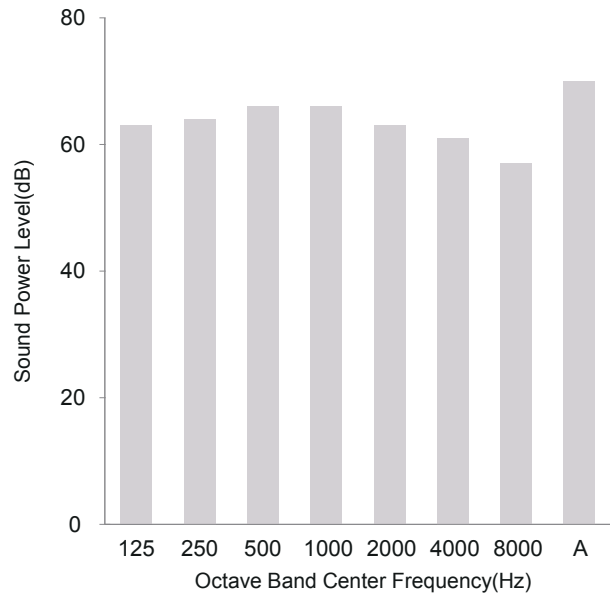

3) AC250KNHPKH/AR (ODU : AC250KXAPNH/AR)

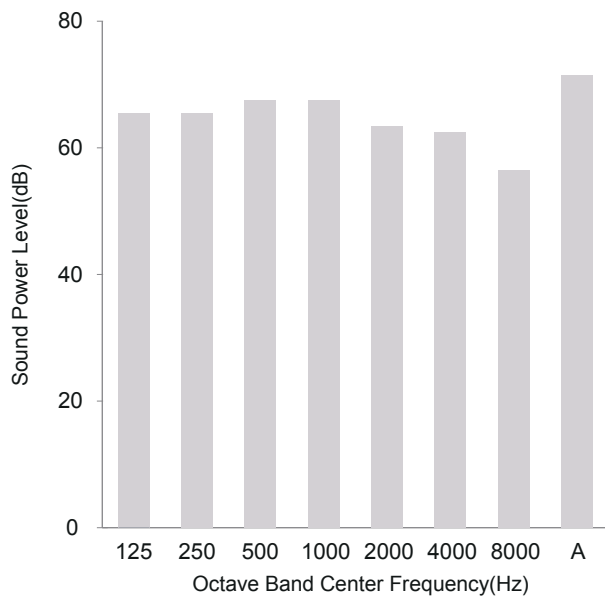

6 Sound power level

Outdoor

Note

- * Specifications may be subject to change
- 1) dBA = A-weighted sound power level.
- 2) Reference power : 1pW.
- 3) Measured according to ISO 3741.

Unit: dB(A)

Model	Power
AC180JXAPNH/AR (IDU : AC180JNHPKH/AR)	76
AC200KXAPNH/AR (IDU : AC200KNHPKH/AR)	75
AC250KXAPNH/AR (IDU : AC250KNHPKH/AR)	77

1) AC180JXAPNH/AR (IDU : AC180JNHPKH/AR)

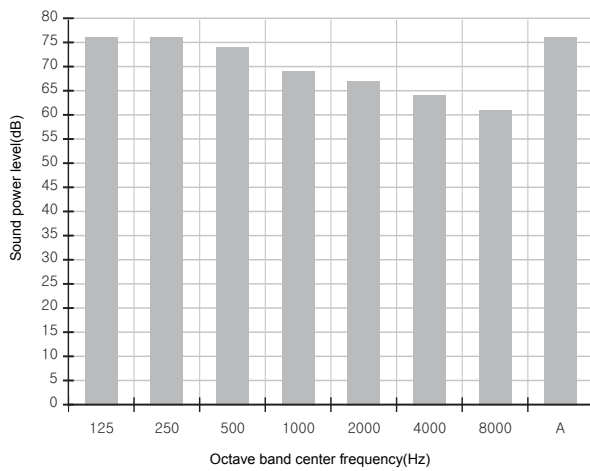

2) AC200KXAPNH/AR (IDU : AC200KNHPKH/AR)

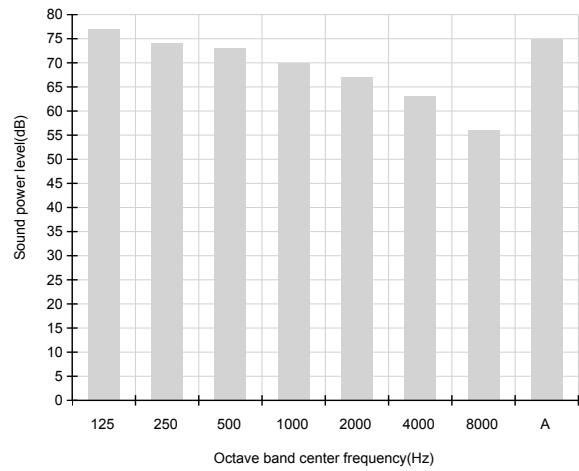

3) AC250KXAPNH/AR (IDU : AC250KNHPKH/AR)

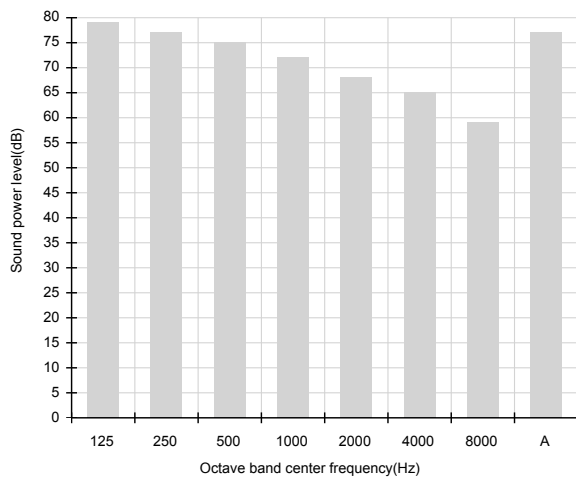

7 Recommended operation range

1) AC180JNHPKH/AR (ODU : AC180JXAPNH/AR)

①	External Static Pressure(mmAq)	Option Code
	5-7.5	01107C-1C50B0-27B414-370060

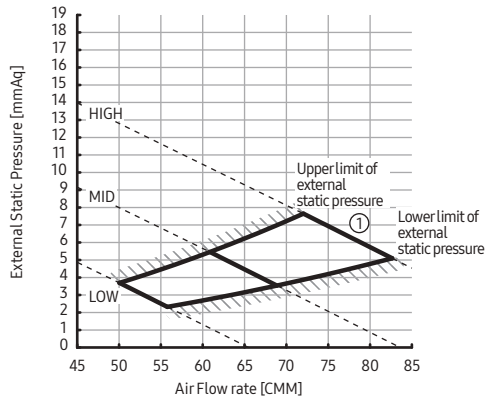

②	External Static Pressure(mmAq)	Option Code
	7.5-10	01107C-1C50E3-27B414-370060

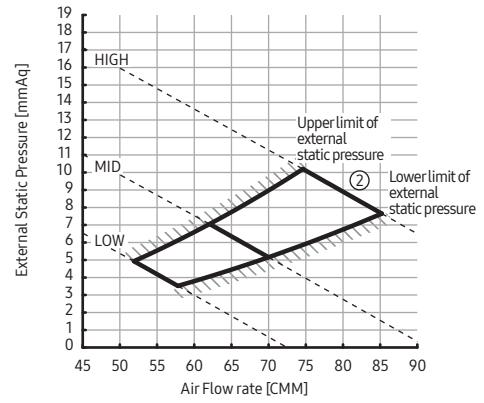

③	External Static Pressure(mmAq)	Option Code
	10-12.5	01107C-1C50F5-27B414-370060

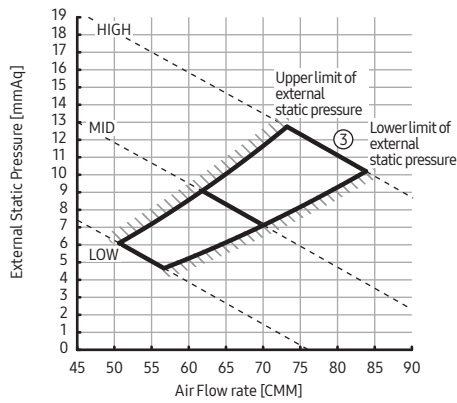

④	External Static Pressure(mmAq)	Option Code
	12.5-15	01107C-1C5436-27B414-370060

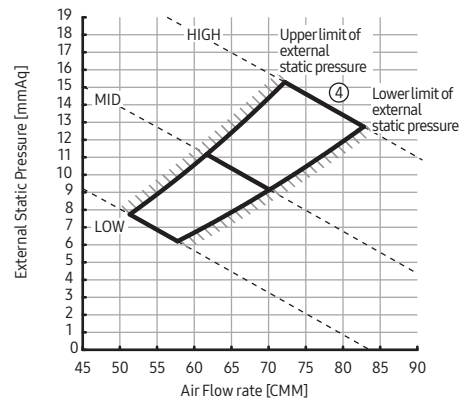

⑤	External Static Pressure(mmAq)	Option Code
	15-17.5	01107C-1C5458-27B414-370060

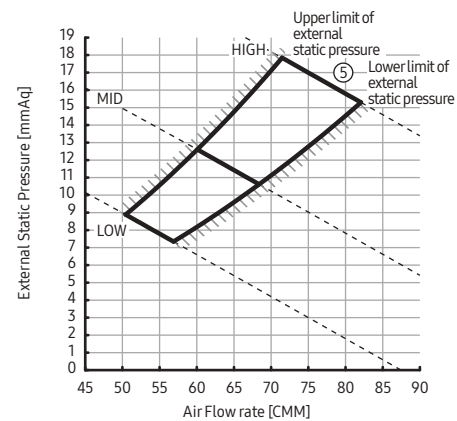

⑥	External Static Pressure(mmAq)	Option Code
	17.5-20	01107C-1C548E-27B414-370060

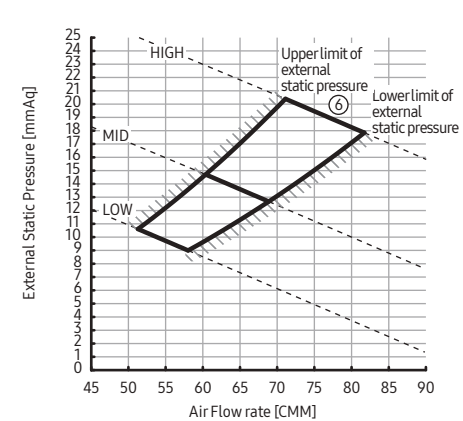

Note

Adjust option code according to the actual installation condition (external static pressure).

The graphs display the available external static pressure range of installed indoor units. Therefore, they do not reflect the actual change of external static pressure and airflow rate according to adjusted airflow (High-Mid-Low) of installed indoor units.

7 Recommended operation range

2) AC200KNHPKH/AR (ODU : AC200KXAPNH/AR)

①	External Static Pressure (mmAq)	Option Code
	5≤P<7.5	011074-1C50C0-27C8E6-372000

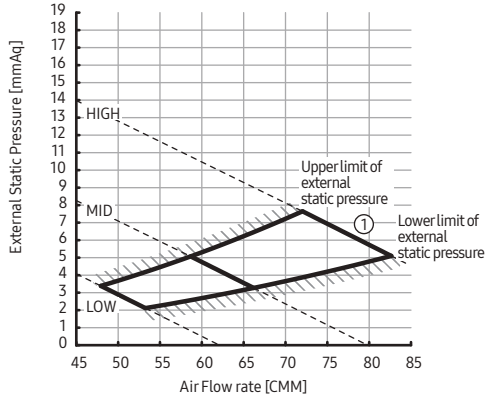

②	External Static Pressure (mmAq)	Option Code
	7.5≤P<10	011074-1C50E3-27C8E6-372000

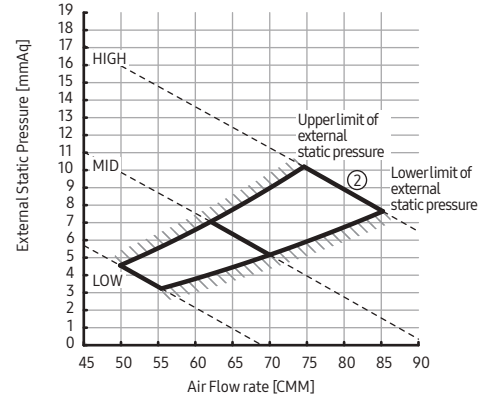

③	External Static Pressure (mmAq)	Option Code
	10≤P<12.5	011074-1C50F5-27C8E6-372000

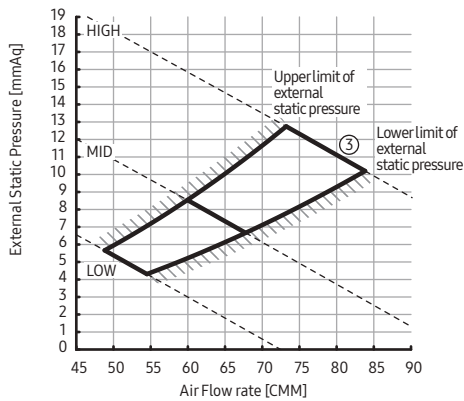

④	External Static Pressure (mmAq)	Option Code
	12.5≤P<15	011074-1C5436-27C8E6-372000

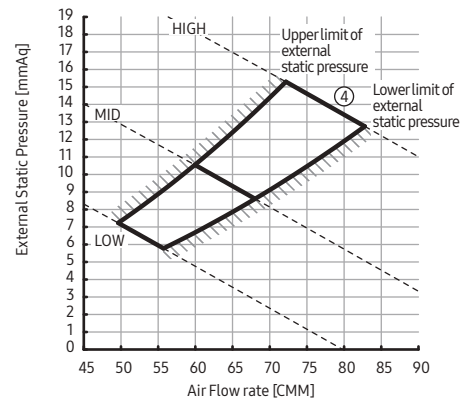

⑤	External Static Pressure (mmAq)	Option Code
	15≤P<17.5	011074-1C5458-27C8E6-372000

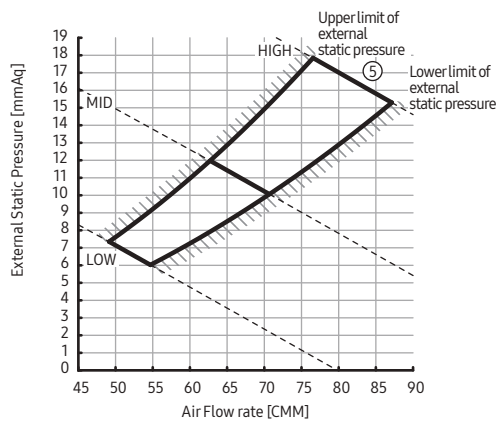

⑥	External Static Pressure (mmAq)	Option Code
	17.5≤P≤20	011074-1C548E-27C8E6-372000

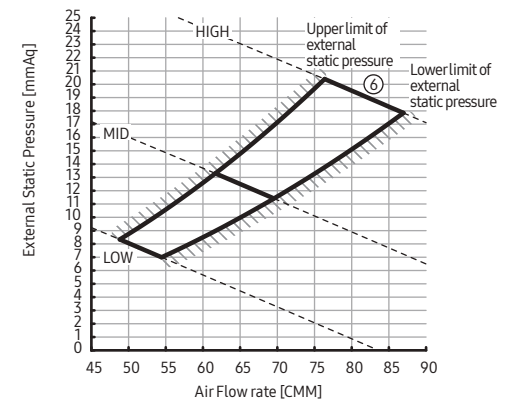

Note

Adjust option code according to the actual installation condition (external static pressure).

The graphs display the available external static pressure range of installed indoor units. Therefore, they do not reflect the actual change of external static pressure and airflow rate according to adjusted airflow (High-Mid-Low) of installed indoor units.

7 Recommended operation range

3) AC250KNHPKH/AR (ODU : AC250KXAPNH/AR)

①	External Static Pressure(mmAq)	Option Code
	5≤P<7.5	011074-1C50F0-270014-373800

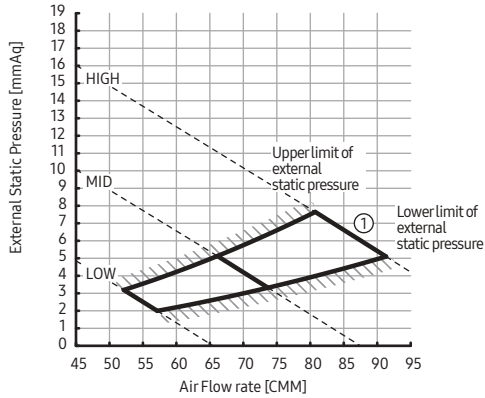

②	External Static Pressure(mmAq)	Option Code
	7.5≤P<10	011074-1C50F3-270014-373800

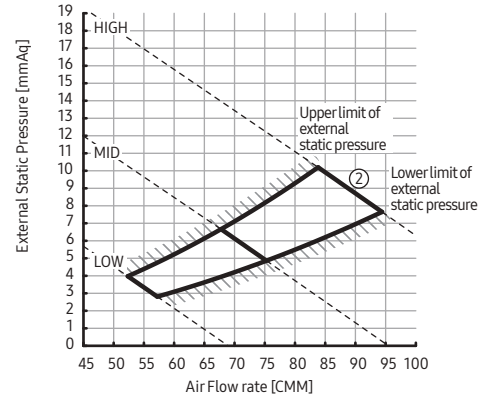

③	External Static Pressure(mmAq)	Option Code
	10≤P<12.5	011074-1C5435-270014-373800

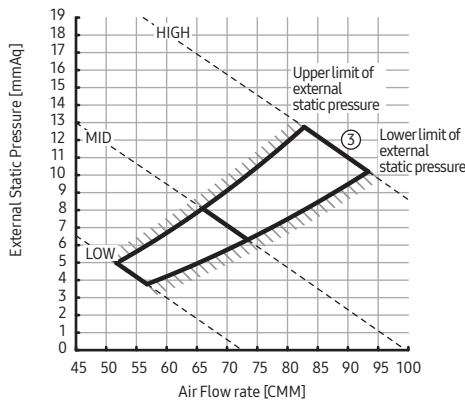

④	External Static Pressure(mmAq)	Option Code
	12.5≤P<15	011074-1C5466-270014-373800

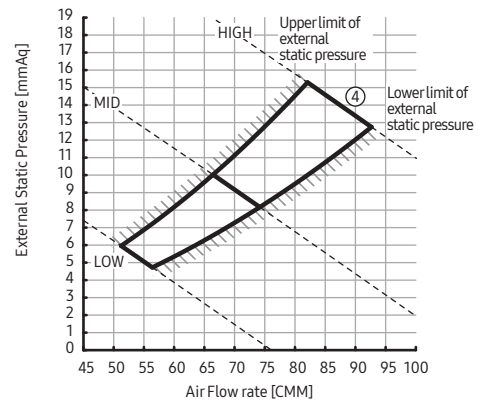

⑤	External Static Pressure(mmAq)	Option Code
	15≤P<17.5	011074-1C5487-270014-373800

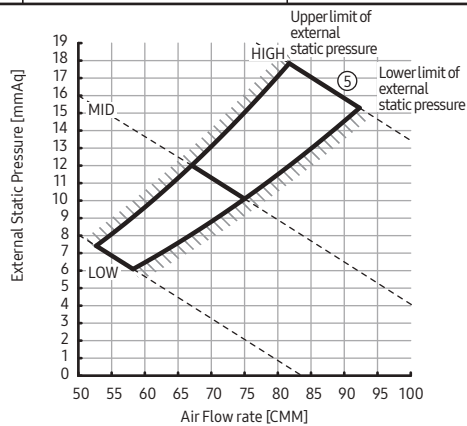

⑥	External Static Pressure(mmAq)	Option Code
	17.5≤P≤20	011074-1C548B-270014-373800

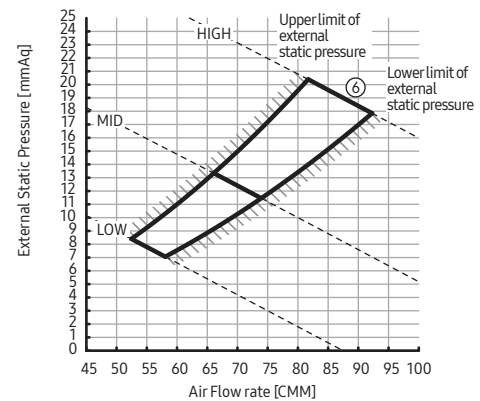

Note

Adjust option code according to the actual installation condition (external static pressure).

The graphs display the available external static pressure range of installed indoor units. Therefore, they do not reflect the actual change of external static pressure and airflow rate according to adjusted airflow (High-Mid-Low) of installed indoor units.

8 Cycle diagram

Outdoor
AC180JXAPNH/AR

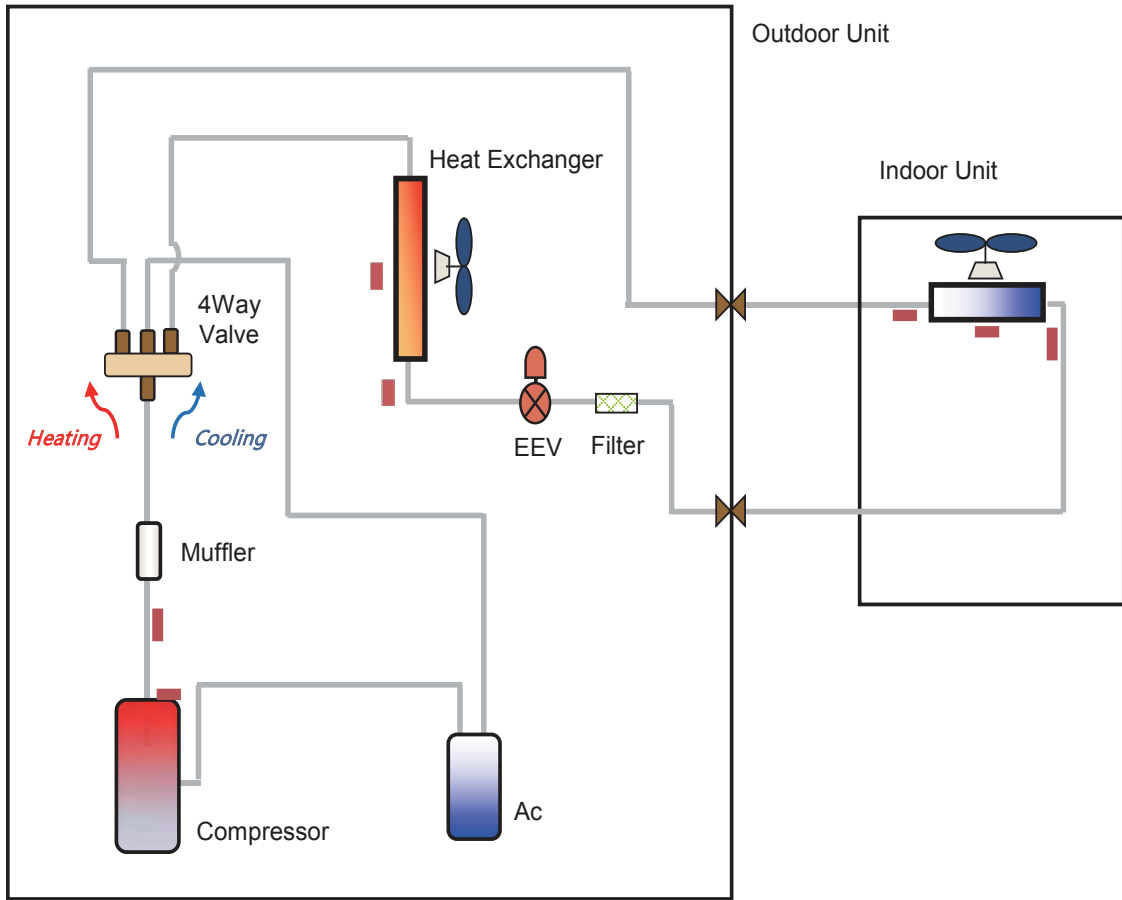

Category		Description
Compressor		Rotary Inverter Compressor
Heat Exchanger		Condensing/Evaporating unit(FMC)
AC		Accumulator
Filter		Filter
Valve	Expansion	Electronic Expansion Valve(EEV)
	Reversing	4 Way valve (Reversing valve)
	Service	Service valve
Sensor	Temperature	Pipe/Air Temperature sensor

8 Cycle diagram

Outdoor

AC200KXAPNH/AR, AC250KXAPNH/AR

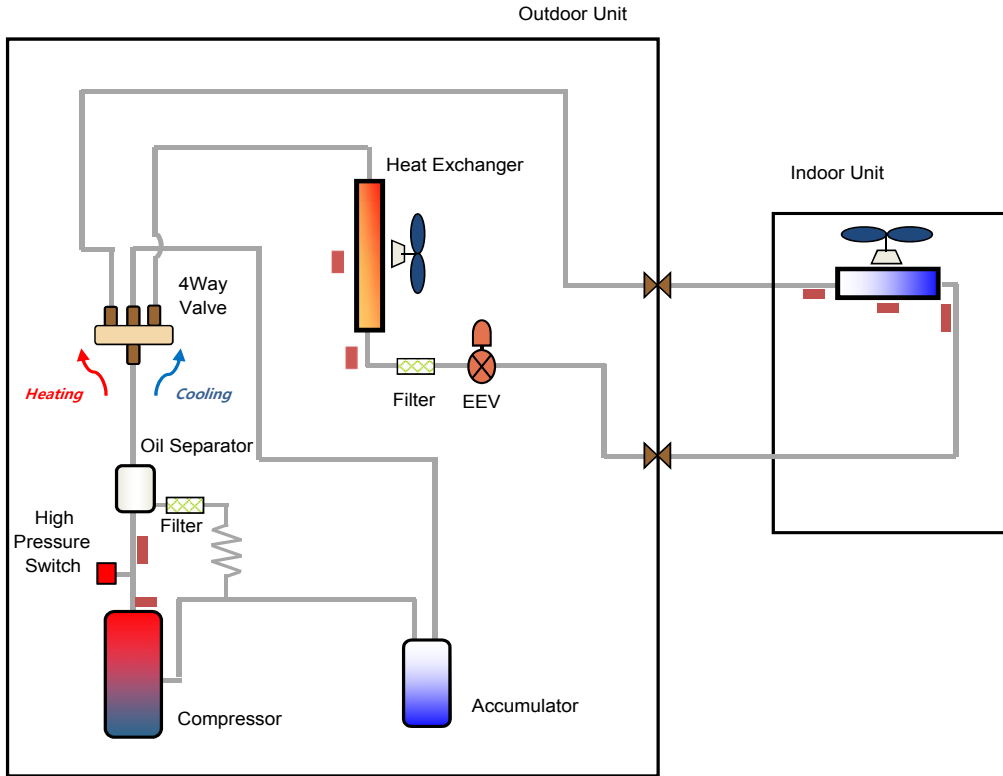

Category	Symbol	Description	
Compressor		Scroll Inverter Compressor.	
Heat Exchanger		Condensing/Evaporating unit	
Accumulator		Accumulator	
Oil Separator		Oil Separator	
Switch		High Pressure Switch	
Filter		Filter	
Valve	Expansion		Electronic Expansion Valve (EEV)
	Reversing		4 Way valve (Reversing valve)
	Service		Service valve
Sensor	Temperature		Pipe/Air Temperature sensor

9 Capacity correction

AC180JNHPKH/AR + AC180JXAPNH/AR

Cooling



Level Difference (m)	Pipe Length (m)															
	5	10	15	20	25	30	35	40	45	50	55	60	65	70	75	
30	-	-	-	-	-	0.93	0.91	0.90	0.89	0.87	0.86	0.84	0.83	0.81	0.80	
25	-	-	-	-	0.94	0.93	0.91	0.90	0.89	0.87	0.86	0.84	0.83	0.81	0.80	
20	-	-	-	0.96	0.94	0.93	0.91	0.90	0.89	0.87	0.86	0.84	0.83	0.81	0.80	
15	-	-	0.97	0.96	0.94	0.93	0.91	0.90	0.89	0.87	0.86	0.84	0.83	0.81	0.80	
10	-	0.99	0.97	0.96	0.94	0.93	0.91	0.90	0.89	0.87	0.86	0.84	0.83	0.81	0.80	
5	1.00	0.99	0.97	0.96	0.94	0.93	0.91	0.90	0.89	0.87	0.86	0.84	0.83	0.81	0.80	
0	1.00	0.99	0.97	0.96	0.94	0.93	0.91	0.90	0.89	0.87	0.86	0.84	0.83	0.81	0.80	
-5	1.00	0.98	0.97	0.95	0.94	0.92	0.91	0.90	0.88	0.87	0.85	0.84	0.83	0.81	0.80	
-10	-	0.97	0.96	0.95	0.93	0.92	0.90	0.89	0.88	0.86	0.85	0.83	0.82	0.81	0.80	
-15	-	-	0.96	0.94	0.93	0.91	0.90	0.89	0.87	0.86	0.84	0.83	0.82	0.81	0.80	
-20	-	-	-	0.94	0.92	0.91	0.90	0.88	0.87	0.85	0.84	0.83	0.81	0.80	0.80	
-25	-	-	-	-	0.92	0.90	0.89	0.88	0.86	0.85	0.83	0.82	0.81	0.80	0.80	
-30	-	-	-	-	-	0.90	0.89	0.87	0.86	0.84	0.83	0.82	0.81	0.80	0.80	

Heating



Level Difference (m)	Pipe Length (m)															
	5	10	15	20	25	30	35	40	45	50	55	60	65	70	75	
30	-	-	-	-	-	0.93	0.91	0.90	0.89	0.87	0.86	0.84	0.83	0.81	0.80	
25	-	-	-	-	0.94	0.93	0.91	0.90	0.89	0.87	0.86	0.84	0.83	0.81	0.80	
20	-	-	-	0.96	0.94	0.93	0.91	0.90	0.89	0.87	0.86	0.84	0.83	0.81	0.80	
15	-	-	0.97	0.96	0.94	0.93	0.91	0.90	0.89	0.87	0.86	0.84	0.83	0.81	0.80	
10	-	0.99	0.97	0.96	0.94	0.93	0.91	0.90	0.89	0.87	0.86	0.84	0.83	0.81	0.80	
5	1.00	0.99	0.97	0.96	0.94	0.93	0.91	0.90	0.89	0.87	0.86	0.84	0.83	0.81	0.80	
0	1.00	0.99	0.97	0.96	0.94	0.93	0.91	0.90	0.89	0.87	0.86	0.84	0.83	0.81	0.80	
-5	1.00	0.99	0.97	0.96	0.94	0.93	0.91	0.90	0.89	0.87	0.86	0.84	0.83	0.81	0.80	
-10	-	0.99	0.97	0.96	0.94	0.93	0.91	0.90	0.89	0.87	0.86	0.84	0.83	0.81	0.80	
-15	-	-	0.97	0.96	0.94	0.93	0.91	0.90	0.89	0.87	0.86	0.84	0.83	0.81	0.80	
-20	-	-	-	0.96	0.94	0.93	0.91	0.90	0.89	0.87	0.86	0.84	0.83	0.81	0.80	
-25	-	-	-	-	0.94	0.93	0.91	0.90	0.89	0.87	0.86	0.84	0.83	0.81	0.80	
-30	-	-	-	-	-	0.93	0.91	0.90	0.89	0.87	0.86	0.84	0.83	0.81	0.80	

AC200KNHPKH/AR + AC200KXAPNH/AR

Cooling



Level Difference (m)	Pipe Length (m)															
	5	10	15	20	25	30	35	40	45	50	55	60	65	70	75	
30	-	-	-	-	-	0.90	0.88	0.86	0.84	0.82	0.80	0.78	0.76	0.74	0.72	
25	-	-	-	-	0.92	0.90	0.88	0.86	0.84	0.82	0.80	0.78	0.76	0.74	0.72	
20	-	-	-	0.94	0.92	0.90	0.88	0.86	0.84	0.82	0.80	0.78	0.76	0.74	0.72	
15	-	-	0.96	0.94	0.92	0.90	0.88	0.86	0.84	0.82	0.80	0.78	0.76	0.74	0.72	
10	-	0.98	0.96	0.94	0.92	0.90	0.88	0.86	0.84	0.82	0.80	0.78	0.76	0.74	0.72	
5	1.00	0.98	0.96	0.94	0.92	0.90	0.88	0.86	0.84	0.82	0.80	0.78	0.76	0.74	0.72	
0	1.00	0.98	0.96	0.94	0.92	0.90	0.88	0.86	0.84	0.82	0.80	0.78	0.76	0.74	0.72	
-5	1.00	0.98	0.96	0.94	0.92	0.90	0.88	0.86	0.84	0.82	0.80	0.78	0.76	0.74	0.72	
-10	-	0.97	0.95	0.93	0.91	0.89	0.87	0.85	0.83	0.81	0.79	0.77	0.75	0.73	0.71	
-15	-	-	0.95	0.93	0.91	0.89	0.87	0.85	0.83	0.81	0.79	0.77	0.75	0.73	0.71	
-20	-	-	-	0.92	0.90	0.88	0.86	0.84	0.82	0.80	0.78	0.76	0.74	0.72	0.70	
-25	-	-	-	-	0.90	0.88	0.86	0.84	0.82	0.80	0.78	0.76	0.74	0.72	0.70	
-30	-	-	-	-	-	0.87	0.85	0.83	0.81	0.79	0.77	0.75	0.73	0.71	0.69	

Heating



Level Difference (m)	Pipe Length (m)															
	5	10	15	20	25	30	35	40	45	50	55	60	65	70	75	
30	-	-	-	-	-	0.96	0.96	0.95	0.94	0.94	0.93	0.92	0.91	0.91	0.90	
25	-	-	-	-	0.97	0.96	0.96	0.95	0.94	0.94	0.93	0.92	0.91	0.91	0.90	
20	-	-	-	0.98	0.97	0.96	0.96	0.95	0.94	0.94	0.93	0.92	0.91	0.91	0.90	
15	-	-	0.99	0.98	0.97	0.96	0.96	0.95	0.94	0.94	0.93	0.92	0.91	0.91	0.90	
10	-	0.99	0.99	0.98	0.97	0.96	0.96	0.95	0.94	0.94	0.93	0.92	0.91	0.91	0.90	
5	1.00	0.99	0.99	0.98	0.97	0.96	0.96	0.95	0.94	0.94	0.93	0.92	0.91	0.91	0.90	
0	1.00	0.99	0.99	0.98	0.97	0.96	0.96	0.95	0.94	0.94	0.93	0.92	0.91	0.91	0.90	
-5	1.00	0.99	0.99	0.98	0.97	0.96	0.96	0.95	0.94	0.94	0.93	0.92	0.91	0.91	0.90	
-10	-	0.99	0.99	0.98	0.97	0.96	0.96	0.95	0.94	0.94	0.93	0.92	0.91	0.91	0.90	
-15	-	-	0.99	0.98	0.97	0.96	0.96	0.95	0.94	0.94	0.93	0.92	0.91	0.91	0.90	
-20	-	-	-	0.98	0.97	0.96	0.96	0.95	0.94	0.94	0.93	0.92	0.91	0.91	0.90	
-25	-	-	-	-	0.97	0.96	0.96	0.95	0.94	0.94	0.93	0.92	0.91	0.91	0.90	
-30	-	-	-	-	-	0.96	0.96	0.95	0.94	0.94	0.93	0.92	0.91	0.91	0.90	

9 Capacity correction

AC250KNHPKH/AR + AC250KXAPNH/AR

Cooling



		Pipe Length (m)														
		5	10	15	20	25	30	35	40	45	50	55	60	65	70	75
Level Difference (m)	30	-	-	-	-	-	0.88	0.86	0.83	0.81	0.79	0.76	0.74	0.72	0.69	0.67
	25	-	-	-	-	0.91	0.88	0.86	0.83	0.81	0.79	0.76	0.74	0.72	0.69	0.67
	20	-	-	-	0.93	0.91	0.88	0.86	0.83	0.81	0.79	0.76	0.74	0.72	0.69	0.67
	15	-	-	0.95	0.93	0.91	0.88	0.86	0.83	0.81	0.79	0.76	0.74	0.72	0.69	0.67
	10	-	0.98	0.95	0.93	0.91	0.88	0.86	0.83	0.81	0.79	0.76	0.74	0.72	0.69	0.67
	5	1.00	0.98	0.95	0.93	0.91	0.88	0.86	0.83	0.81	0.79	0.76	0.74	0.72	0.69	0.67
	0	1.00	0.98	0.95	0.93	0.91	0.88	0.86	0.83	0.81	0.79	0.76	0.74	0.72	0.69	0.67
	-5	1.00	0.98	0.95	0.93	0.91	0.88	0.86	0.83	0.81	0.79	0.76	0.74	0.72	0.69	0.67
	-10	-	0.97	0.94	0.92	0.90	0.87	0.85	0.82	0.80	0.78	0.75	0.73	0.71	0.68	0.66
	-15	-	-	0.94	0.92	0.90	0.87	0.85	0.82	0.80	0.78	0.75	0.73	0.71	0.68	0.66
	-20	-	-	-	0.91	0.89	0.86	0.84	0.81	0.79	0.77	0.74	0.72	0.70	0.67	0.65
	-25	-	-	-	-	0.89	0.86	0.84	0.81	0.79	0.77	0.74	0.72	0.70	0.67	0.65
	-30	-	-	-	-	-	0.86	0.84	0.81	0.79	0.77	0.74	0.72	0.70	0.67	0.65

Heating



		Pipe Length (m)														
		5	10	15	20	25	30	35	40	45	50	55	60	65	70	75
Level Difference (m)	30	-	-	-	-	-	0.96	0.96	0.95	0.94	0.94	0.93	0.92	0.91	0.91	0.90
	25	-	-	-	-	0.97	0.96	0.96	0.95	0.94	0.94	0.93	0.92	0.91	0.91	0.90
	20	-	-	-	0.98	0.97	0.96	0.96	0.95	0.94	0.94	0.93	0.92	0.91	0.91	0.90
	15	-	-	0.99	0.98	0.97	0.96	0.96	0.95	0.94	0.94	0.93	0.92	0.91	0.91	0.90
	10	-	0.99	0.99	0.98	0.97	0.96	0.96	0.95	0.94	0.94	0.93	0.92	0.91	0.91	0.90
	5	1.00	0.99	0.99	0.98	0.97	0.96	0.96	0.95	0.94	0.94	0.93	0.92	0.91	0.91	0.90
	0	1.00	0.99	0.99	0.98	0.97	0.96	0.96	0.95	0.94	0.94	0.93	0.92	0.91	0.91	0.90
	-5	1.00	0.99	0.99	0.98	0.97	0.96	0.96	0.95	0.94	0.94	0.93	0.92	0.91	0.91	0.90
	-10	-	0.99	0.99	0.98	0.97	0.96	0.96	0.95	0.94	0.94	0.93	0.92	0.91	0.91	0.90
	-15	-	-	0.99	0.98	0.97	0.96	0.96	0.95	0.94	0.94	0.93	0.92	0.91	0.91	0.90
	-20	-	-	-	0.98	0.97	0.96	0.96	0.95	0.94	0.94	0.93	0.92	0.91	0.91	0.90
	-25	-	-	-	-	0.97	0.96	0.96	0.95	0.94	0.94	0.93	0.92	0.91	0.91	0.90
	-30	-	-	-	-	-	0.96	0.96	0.95	0.94	0.94	0.93	0.92	0.91	0.91	0.90

Big Ceiling

1 Specifications

2 Capacity table

3 Dimensional drawing

4 Electrical wiring diagram

5 Sound pressure level

6 Sound power level

7 Temperature and air flow distribution

8 Cycle diagram

9 Capacity correction

1 Specifications

Big Ceiling

Type			Indoor Unit	Ceiling	Ceiling		
Model Name	Indoor Unit			AC140JNCDEH/AR	AC160JNCDEH/AR		
	Outdoor Unit			AC140JXADGH/AR	AC160JXADGH/AR		
System	Mode		-	Heat Pump	Heat Pump		
	Capacity	Cooling(Min/Std/Max)		kW	4.30 / 14.00 / 15.40	4.30 / 15.00 / 17.30	
				Btu/h	14,700 / 47,800 / 52,500	14,700 / 51,200 / 59,000	
		Heating(Min/Std/Max)		kW	4.70 / 16.00 / 18.00	4.70 / 17.50 / 19.00	
				Btu/h	16,000 / 54,600 / 61,400	16,000 / 59,700 / 64,800	
	Power	Power Input (Nominal)	Cooling(Min/Std/Max)	kW	0.90 / 4.65 / 5.50	0.90 / 5.28 / 6.40	
			Heating(Min/Std/Max)	kW	0.80 / 4.43 / 5.70	0.80 / 4.86 / 6.50	
		Current Input (Nominal)	Cooling(Min/Std/Max)	A	1.70 / 7.10 / 9.50	1.70 / 8.20 / 9.80	
			Heating(Min/Std/Max)	A	1.70 / 6.80 / 8.80	1.70 / 7.50 / 10.00	
		MCA		A	14.70 (MCA)	14.70 (MCA)	
		MFA		A	16.20	16.20	
	Energy Efficiency	EER (Nominal Cooling)		-	3.01	2.84	
		COP (Nominal Heating)		-	3.61	3.60	
		Energy Grade		-	-	-	
	Piping Connections	Liquid Pipe		Ø, mm	9.52	9.52	
				Ø, inch	3/8"	3/8"	
		Gas Pipe		Ø, mm	15.88	15.88	
				Ø, inch	5/8"	5/8"	
		Installation Limitation	Max. Length	m	75	75	
			Max. Height	m	30	30	
	Field Wiring	Power Source Wire		Ø, mm	-	-	
		Transmission Cable		Ø, mm	0.75 ~ 1.50	0.75 ~ 1.50	
	Refrigerant	Type		-	R410A	R410A	
Control Method		-	-	-			
Factory Charging		kg / tCO2e	3.20 / 6.68	3.50 / 7.31			
Indoor Unit	Power Supply		Ø, #, V, Hz	1,2,220-240,50	1,2,220-240,50		
	Fan	Type		-	Sirroco	Sirroco	
		Motor	Output		W	244 x 1	244 x 1
			CMM			34.00 / 27.00 / 23.00	37.00 / 31.00 / 26.00
		Air Flow Rate		High/Mid/Low	l/s	566.67 / 450.00 / 383.33	616.67 / 516.67 / 433.33
	External Static Pressure		Min/Std/Max	mmAq	-	-	
				Pa	-	-	
	Drain	Drain Pipe		Ø,mm	VP20 (OD 25,ID 20)	VP20 (OD 25,ID 20)	
		Sound	Pressure	High/Mid/Low		46 / 42 / 38	50 / 47 / 43
	Power		Cooling	dB(A)	64	68	
	External Dimension	Net Weight		kg	42.0	42.0	
		Shipping Weight		kg	48.0	48.0	
		Net Dimensions (WxHxD)		mm	1,650 x 235 x 675	1,650 x 235 x 675	
		Shipping Dimensions (WxHxD)		mm	1,739 x 321 x 758	1,739 x 321 x 758	
	Panel Size	Panel model		-	-	-	
		Panel Net Weight		kg	-	-	
		Shipping Weight		kg	-	-	
		Net Dimensions (WxHxD)		mm	-	-	
	Shipping Dimensions (WxHxD)		mm	-	-		
	Additional Accessories	Drain pump	Drain pump	-	-	-	
			Max. Lifting	mm/liter/h	-	-	
	Air Filter		-	-	-		
	Outdoor Unit	Power Supply		Ø, #, V, Hz	3,4,380-415,50	1,2,220-240,50	
Compressor		Type		-	Twin BLDC Rotary	Twin BLDC Rotary	
		Model		-	UG5T450FUFJX	UG5T450FXAJX	
		Output		kW	4.12	4.01	
Oil		Type		-	POE	PVE	
		Fan	Air Flow Rate	Cooling	CMM	100.00	115.00
I/s				1,666.67	1,916.67		
Sound		Pressure	Cooling/Heating	dB(A)	53 / 54	55 / 57	
		Power	Cooling	dB(A)	70	73	
External Dimension		Net Weight		kg	90.0	96.0	
		Shipping Weight		kg	100.0	106.0	
		Net Dimensions (WxHxD)		mm	940 x 1,210 x 330	940 x 1,420 x 330	
		Shipping Dimensions (WxHxD)		mm	995 x 1,388 x 426	995 x 1,598 x 426	
Operating Temp. Range		Cooling		°C	-15 ~ 50	-15 ~ 50	
		Heating		°C	-20 ~ 24	-20 ~ 24	

* Specifications may be subject to change without prior notice.

1) Nominal cooling capacities are based on;

- Indoor temperature : 27°C DB, 19°C WB

- Outdoor temperature : 35°C DB, 24°C WB, Equivalent refrigerant piping : 5m, Level differences : 0m

2) Nominal heating capacities are based on;

- Indoor temperature : 20°C DB, 15°C WB

- Outdoor temperature : 7°C DB, 6°C WB, Equivalent refrigerant piping : 5m, Level differences : 0m

3) Sound pressure was acquired in an anechoic room. Thus actual noise level may be different depending on the installation conditions.

4) These products contain R410A(GWP=2,088) which is fluorinated greenhouse gas.

2 Capacity table

Big Ceiling

AC140JNCDEH/AR + AC140JXADGH/AR

Cooling

TC(Total Capacity), SHC(Sensible Heat Capacity), PI(Power Input)

Outdoor temperature (°C, DB)	Indoor temperature (°C, WB)																	
	14.0			16.0			18.0			19.0			22.0			24.0		
	TC	SHC	PI	TC	SHC	PI	TC	SHC	PI	TC	SHC	PI	TC	SHC	PI	TC	SHC	PI
	kW	kW	kW	kW	kW	kW	kW	kW	kW	kW	kW	kW	kW	kW	kW	kW	kW	kW
-15.0	10.30	8.24	3.30	10.55	8.44	3.38	10.81	8.65	3.46	11.08	8.86	3.55	11.35	9.08	3.64	11.62	9.29	3.72
21.0	14.84	11.87	4.68	15.20	12.16	4.80	15.58	12.46	4.92	15.96	12.77	5.04	16.34	13.07	5.16	16.74	13.39	5.28
35.0	13.02	10.41	4.32	13.34	10.67	4.43	13.66	10.93	4.54	14.00	11.20	4.65	14.34	11.47	4.76	14.68	11.74	4.88
46.0	8.96	7.17	3.93	9.18	7.35	4.03	9.41	7.53	4.13	9.64	7.71	4.23	9.87	7.90	4.33	10.11	8.09	4.44
50.0	6.02	2.09	1.33	6.17	2.14	1.36	6.32	2.20	1.40	6.48	5.18	3.17	6.64	5.31	3.93	6.79	5.44	4.03

Heating

TC : Total Capacity PI: Power Input

Outdoor temperature (°C, DB)	Indoor temperature (°C, DB)											
	16.0		18.0		20.0		21.0		22.0		24.0	
	TC	PI	TC	PI	TC	PI	TC	PI	TC	PI	TC	PI
	kW	kW	kW	kW	kW	kW	kW	kW	kW	kW	kW	kW
-20.0	9.67	4.26	9.57	4.22	9.48	4.18	9.38	4.14	9.29	4.10	9.20	4.06
-10.0	13.87	5.71	13.74	5.66	13.60	5.60	13.46	5.54	13.33	5.49	13.20	5.43
7.0	16.32	4.52	16.16	4.47	16.00	4.43	15.84	4.39	15.68	4.34	15.52	4.30
24.0	19.98	4.60	19.79	4.56	19.59	4.51	19.39	4.46	19.20	4.42	19.01	4.38

AC160JNCDEH/AR + AC160JXADGH/AR

Cooling

TC(Total Capacity), SHC(Sensible Heat Capacity), PI(Power Input)

Outdoor temperature (°C, DB)	Indoor temperature (°C, WB)																	
	14.0			16.0			18.0			19.0			22.0			24.0		
	TC	SHC	PI	TC	SHC	PI	TC	SHC	PI	TC	SHC	PI	TC	SHC	PI	TC	SHC	PI
	kW	kW	kW	kW	kW	kW	kW	kW	kW	kW	kW	kW	kW	kW	kW	kW	kW	kW
-15.0	13.95	11.16	2.23	14.29	11.43	2.29	14.64	11.71	2.34	15.00	12.00	2.40	15.36	12.29	2.46	15.73	12.58	2.52
21.0	15.81	12.65	4.00	16.20	12.96	4.10	16.60	13.28	4.20	17.01	13.61	4.30	17.42	13.93	4.40	17.84	14.27	4.51
35.0	13.95	11.16	4.91	14.29	11.43	5.03	14.64	11.71	5.15	15.00	12.00	5.28	15.36	12.29	5.41	15.73	12.58	5.54
46.0	12.68	10.15	5.37	12.99	10.39	5.51	13.31	10.65	5.64	13.64	10.91	5.78	13.97	11.17	5.92	14.30	11.44	6.06
50.0	9.46	7.57	4.62	9.70	7.76	4.73	9.94	7.95	4.85	10.18	8.14	4.97	10.42	8.34	5.10	10.67	8.54	5.23

Heating

TC : Total Capacity, PI: Power Input

Outdoor temperature (°C, DB)	Indoor temperature (°C, DB)											
	16.0		18.0		20.0		21.0		22.0		24.0	
	TC	PI	TC	PI	TC	PI	TC	PI	TC	PI	TC	PI
	kW	kW	kW	kW	kW	kW	kW	kW	kW	kW	kW	kW
-20.0	9.91	4.53	9.81	4.48	9.71	4.44	9.61	4.40	9.52	4.35	9.42	4.31
-10.0	16.65	6.81	16.48	6.75	16.32	6.68	16.16	6.61	16.00	6.55	15.84	6.48
7.0	17.85	4.96	17.68	4.91	17.50	4.86	17.33	4.81	17.15	4.76	16.98	4.72
24.0	22.60	5.64	22.37	5.59	22.15	5.53	21.93	5.47	21.71	5.42	21.49	5.37

* Capacity table may be subject to change without prior notice.

1) Capacities are based on following conditions;

. Cooling mode indoor air temperature (°C, DB/WB) : 20/14, 22/16, 25/18, 27/19, 28/20, 30/22, 32/24

. Heating mode outdoor air : 85%RH. However, the condition rated capacity is 7°C DB / 6°C WB.

. Refrigerant piping length : 5m

. Level difference : 0m.

3 Dimensional drawing

Indoor

AC140JNCDEH/AR, AC160JNCDEH/AR

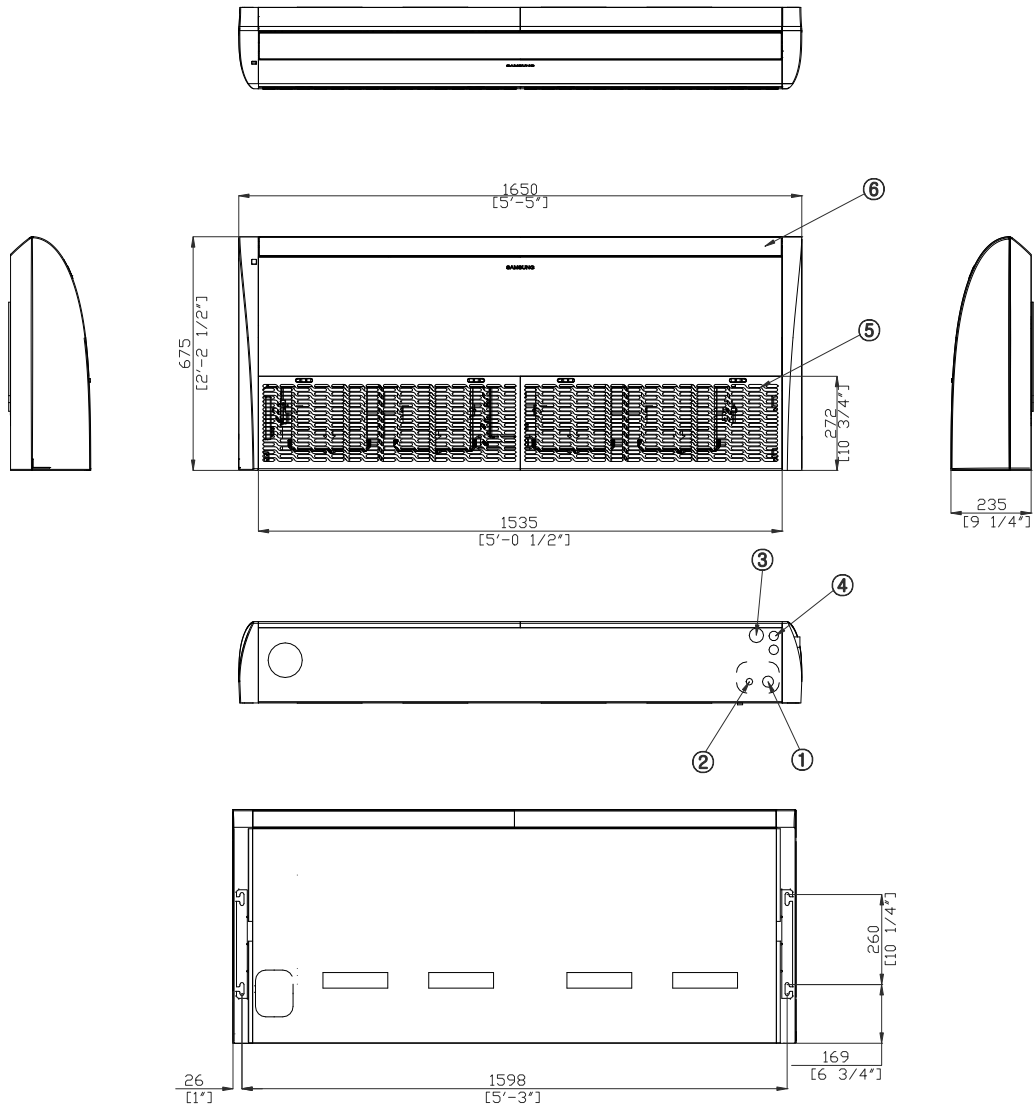

Table of descriptions

1	Refrigerant gas pipe	7	
2	Refrigerant liquid pipe	8	
3	Condensate drain	9	
4	Power&Comm. wiring conduits	10	
5	Air Inlet grille	11	
6	Air Outlet grille	12	

3 Dimensional drawing

Outdoor

AC140JXADGH/AR

Units : mm / inches

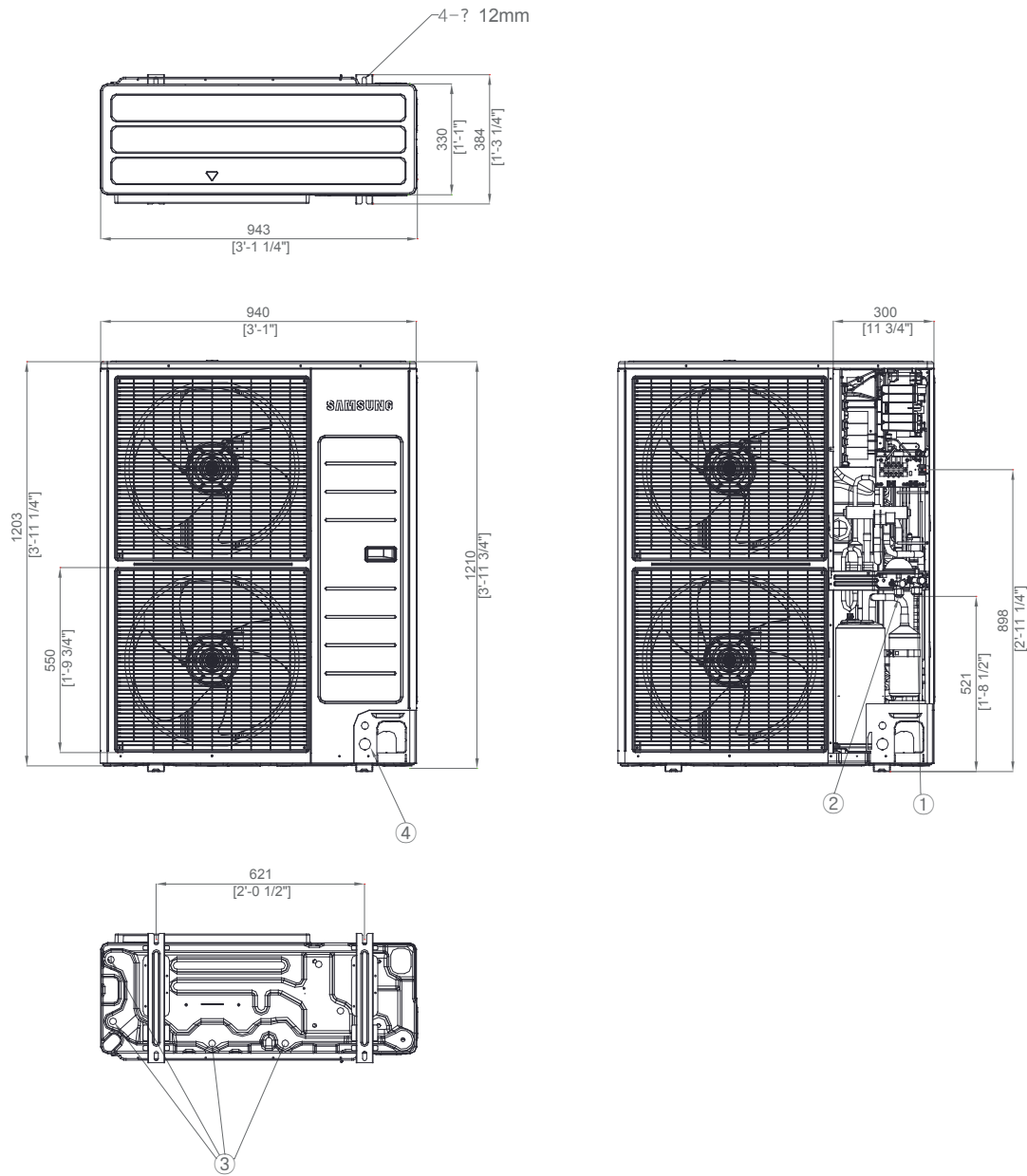

Table of descriptions

1	Refrigerant gas pipe
2	Refrigerant liquid pipe
3	Drain Hole
4	Power & Comm. wiring conduits

3 Dimensional drawing

Outdoor

AC160JXADGH/AR

Units : mm / inches

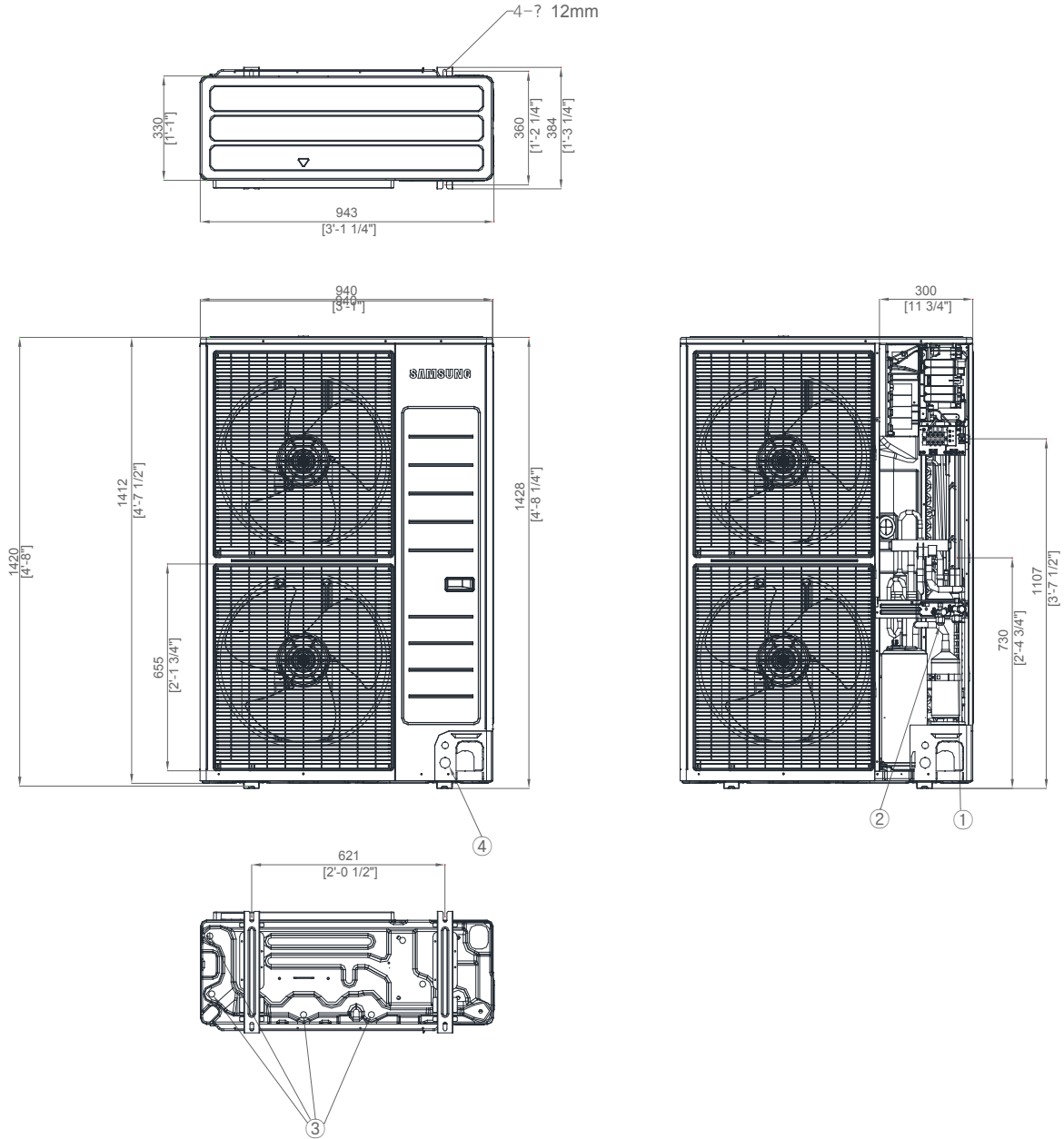

Table of descriptions

1	Refrigerant gas pipe
2	Refrigerant liquid pipe
3	Drain Hole
4	Power & Comm. wiring conduits

4 Electrical wiring diagram

Indoor

AC140JNCDEH/AR, AC160JNCDEH/AR

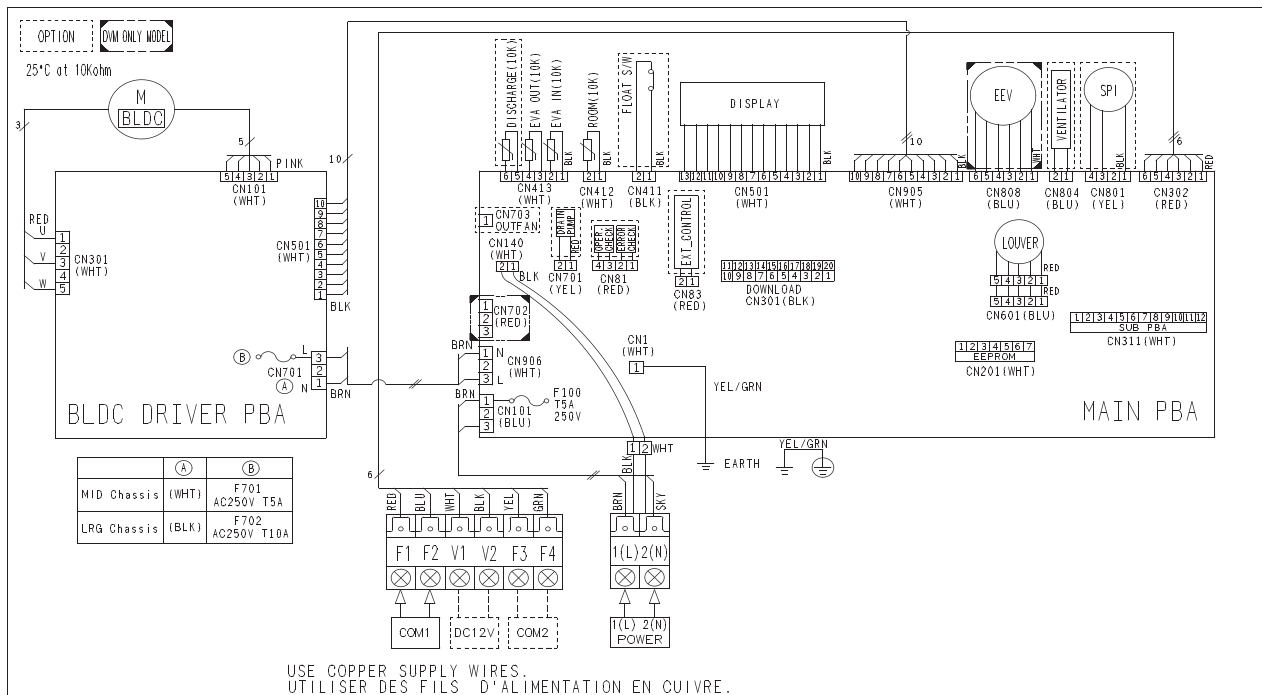

4 Electrical wiring diagram

Outdoor

AC140JXADGH/AR

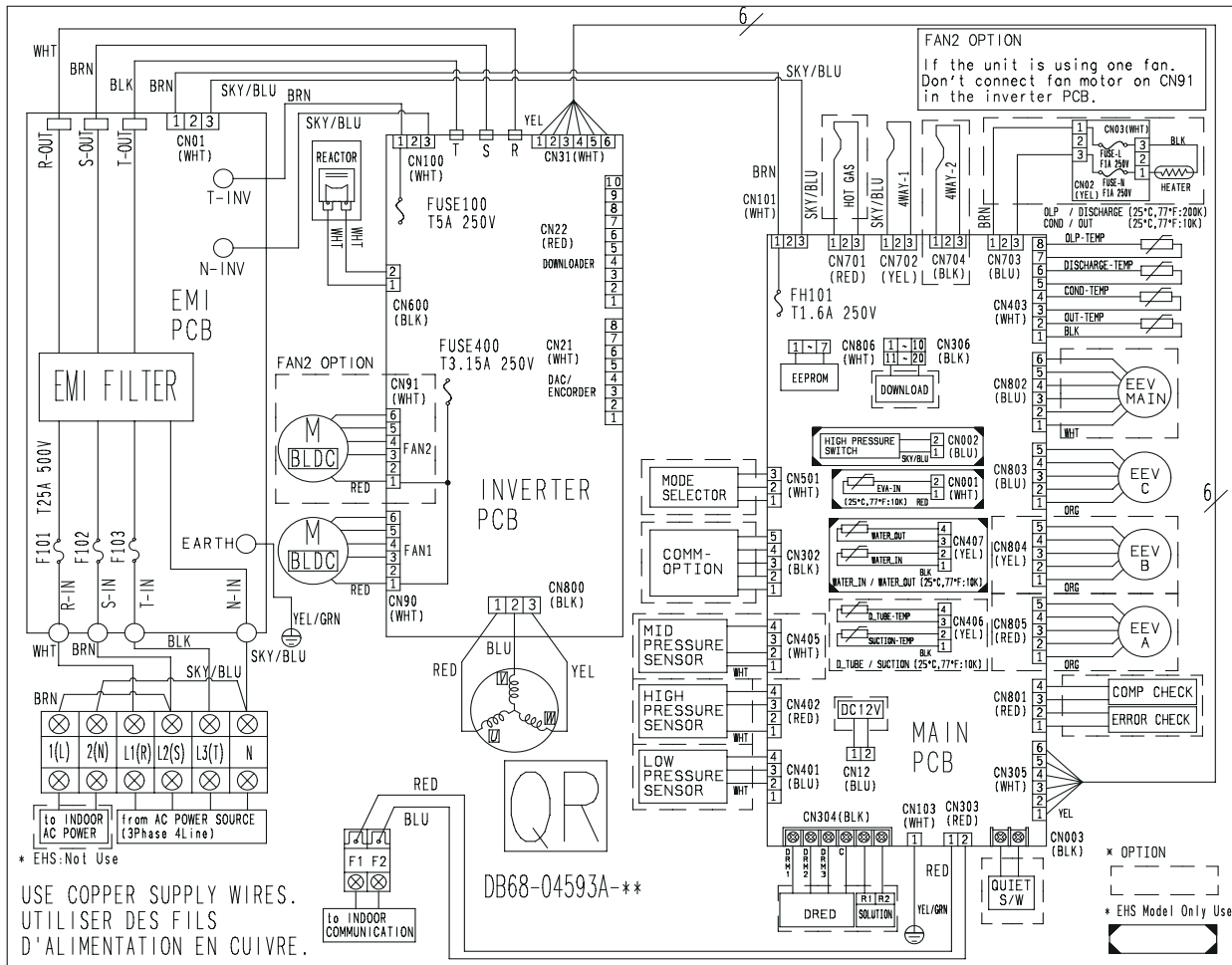

4 Electrical wiring diagram

Outdoor

AC160JXADGH/AR

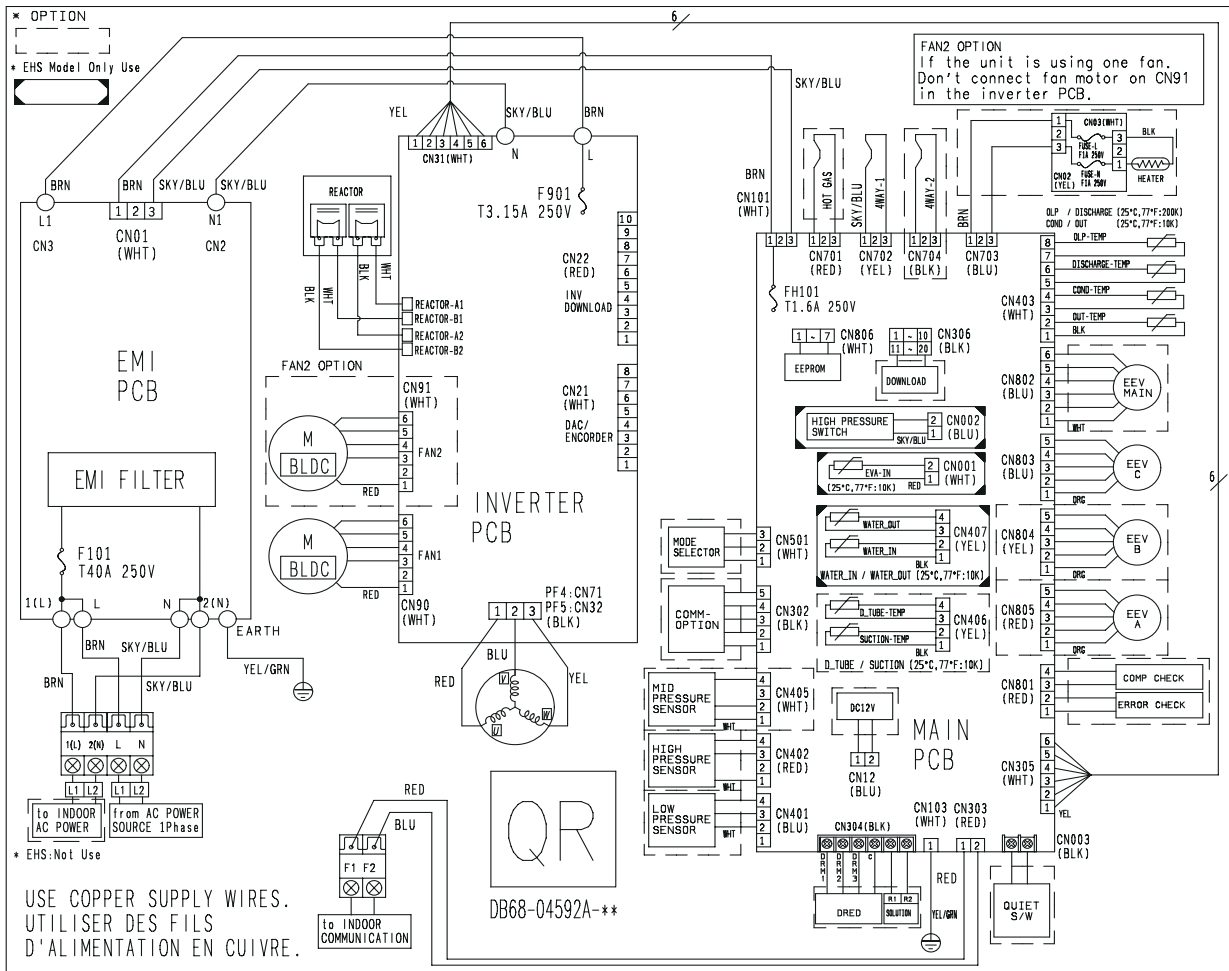

5 Sound pressure level

Indoor

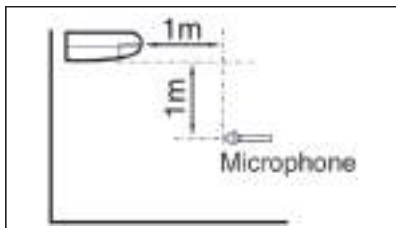

Unit: dB(A)

Model	High	Low
AC140JNCDEH/AR (ODU : AC140JXADGH/AR)	46	38
AC160JNCDEH/AR (ODU : AC160JXADGH/AR)	50	43

Note

* Specifications may be subject to change without prior notice

- 1) These operation values were obtained in an anechoic room.
- 2) Sound pressure level will vary depending on a range of factors such as the construction of the particular room where the equipment is installed.
- 3) Operation sound level may differ depending on operation and ambient conditions.

NC curve

1) AC140JNCDEH/AR (ODU : AC140JXADGH/AR)

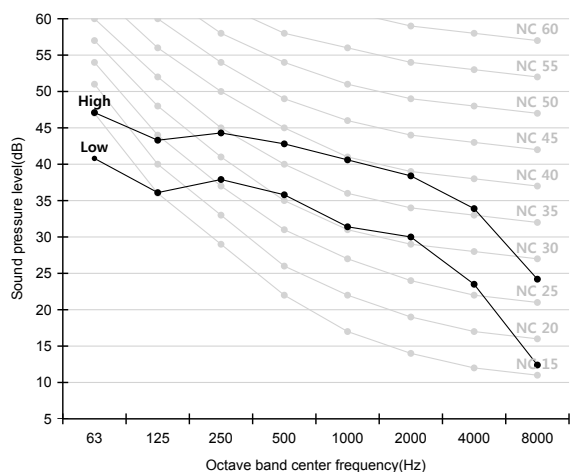

2) AC160JNCDEH/AR (ODU : AC160JXADGH/AR)

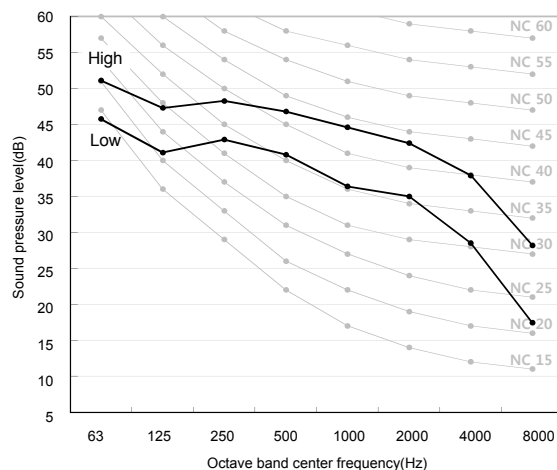

5 Sound pressure level

Outdoor

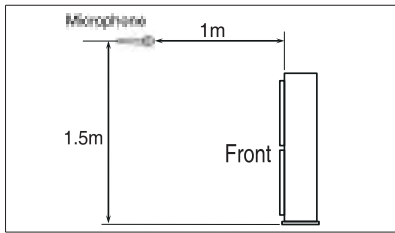

Unit: dB(A)

Model	Cooling	Heating
AC140JXADGH/AR (IDU : AC140JNCDEH/AR)	53	54
AC160JXADGH/AR (IDU : AC160JNCDEH/AR)	55	57

Note

* Specifications may be subject to change without prior notice

1) These operation values were obtained in an anechoic room.

2) Sound pressure level will vary depending on a range of factors such as the construction of the particular room where the equipment is installed.

3) Operation sound level may differ depending on operation and ambient conditions.

NC curve

1) AC140JXADGH/AR (IDU : AC140JNCDEH/AR)

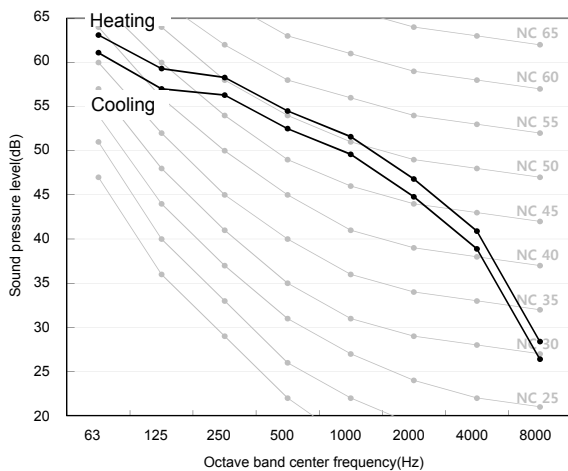

2) AC160JXADGH/AR (IDU : AC160JNCDEH/AR)

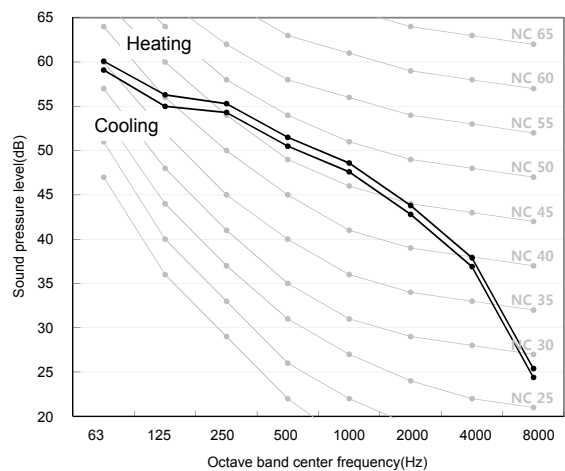

6 Sound power level

Indoor

Note

- * Specifications may be subject to change
- 1) dBA = A-weighted sound power level.
- 2) Reference power : 1pW.
- 3) Measured according to ISO 3741.

Unit: dB(A)

Model	Power
AC140JNCDEH/AR (ODU : AC140JXADGH/AR)	64
AC160JNCDEH/AR (ODU : AC160JXADGH/AR)	68

1) AC140JNCDEH/AR (ODU : AC140JXADGH/AR)

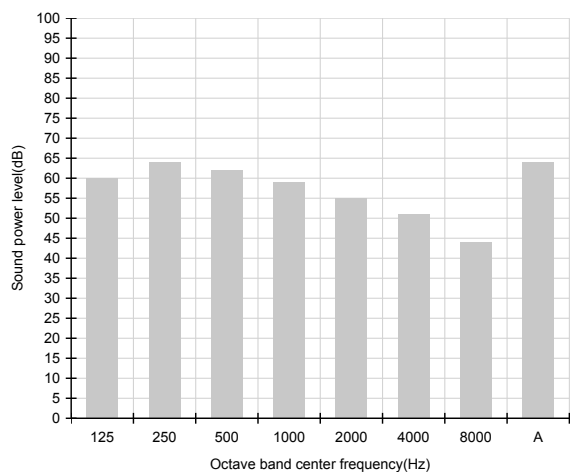

2) AC160JNCDEH/AR (ODU : AC160JXADGH/AR)

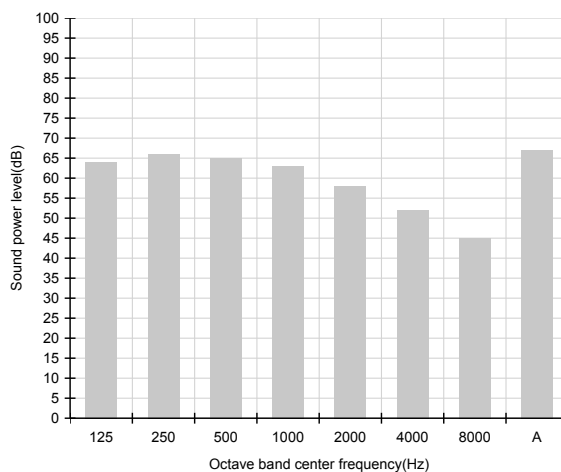

6 Sound power level

Outdoor

Note

- * Specifications may be subject to change
 1) dBA = A-weighted sound power level.
 2) Reference power : 1pW.
 3) Measured according to ISO 3741.

Unit: dB(A)

Model	Power
AC140JXADGH/AR (IDU : AC140JNCDEH/AR)	70
AC160JXADGH/AR (IDU : AC160JNCDEH/AR)	73

1) AC140JXADGH/AR (IDU : AC140JNCDEH/AR)

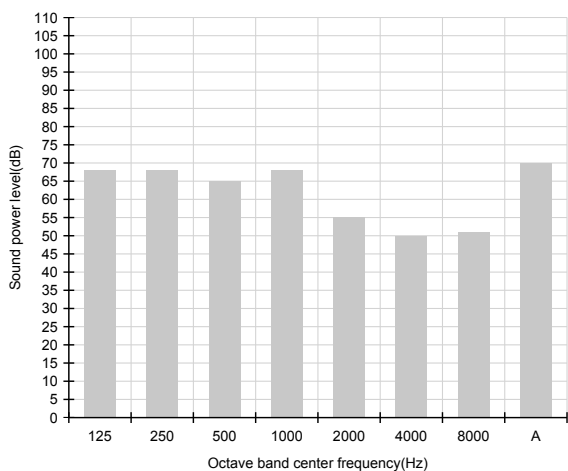

2) AC160JXADGH/AR (IDU : AC160JNCDEH/AR)

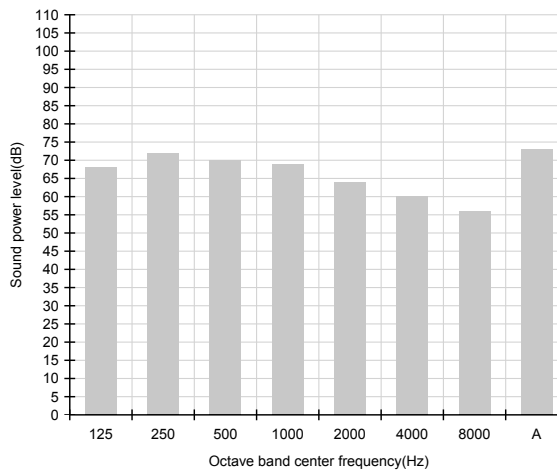

7 Temperature and air flow distribution

AC140JNCDEH/AR

(1) Cooling air velocity distribution

Discharge angle : 32°

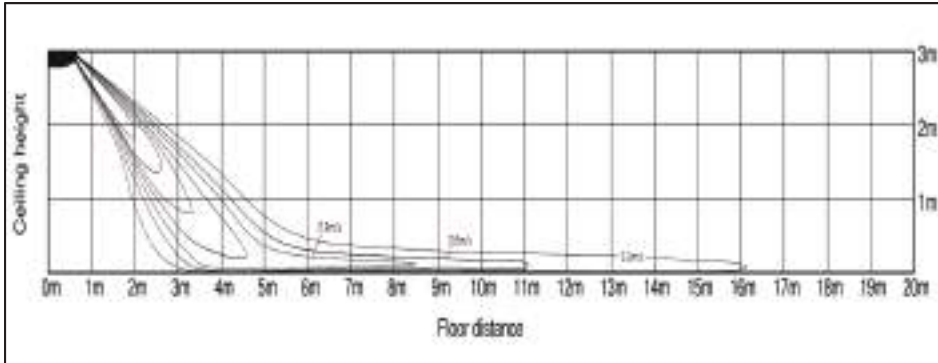

(2) Cooling temperature distribution

Discharge angle : 32°

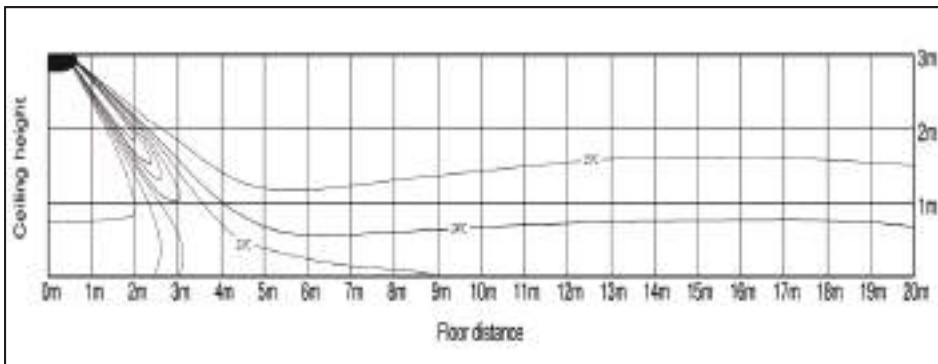

(3) Heating air velocity distribution

Discharge angle : 32°

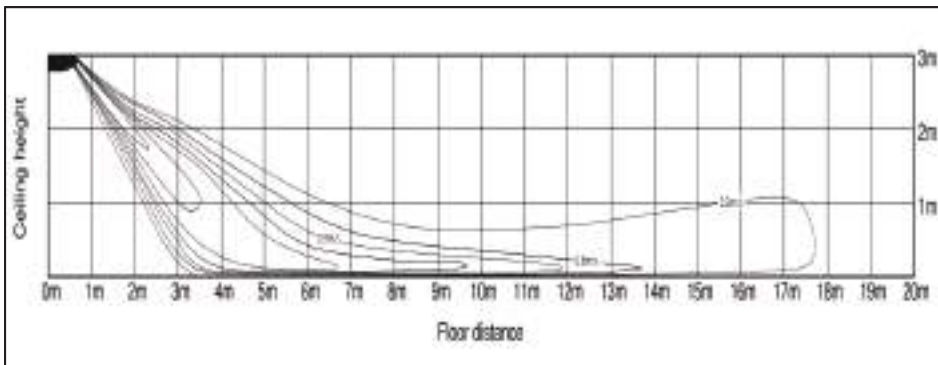

(4) Heating temperature distribution

Discharge angle : 32°

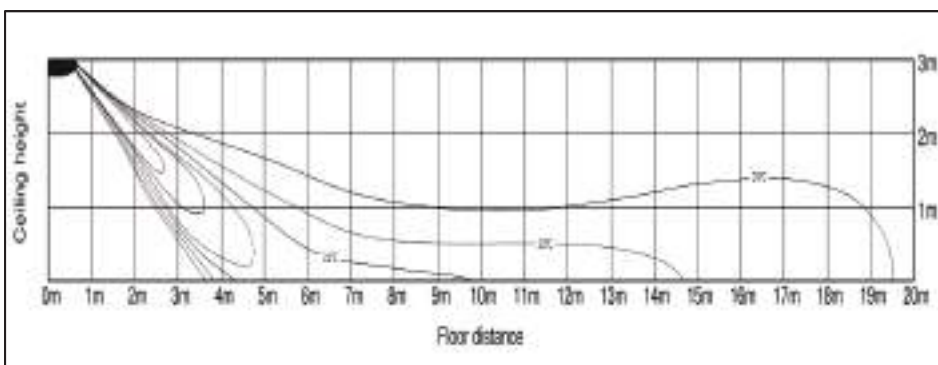

7 Temperature and air flow distribution

AC160JNCDEH/AR

(1) Cooling air velocity distribution

Discharge angle : 32°

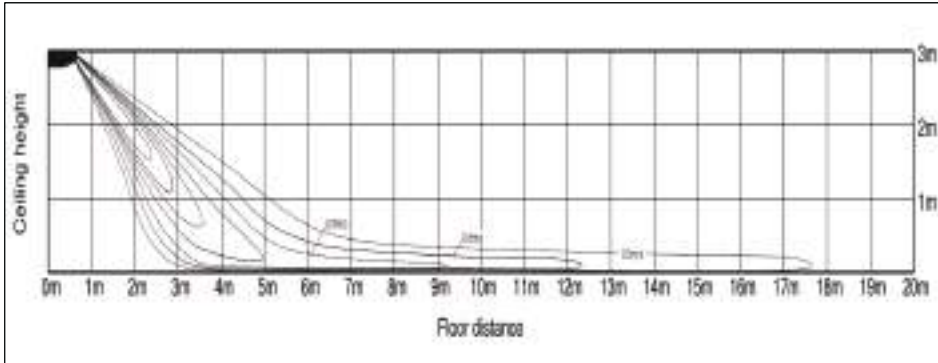

(2) Cooling temperature distribution

Discharge angle : 32°

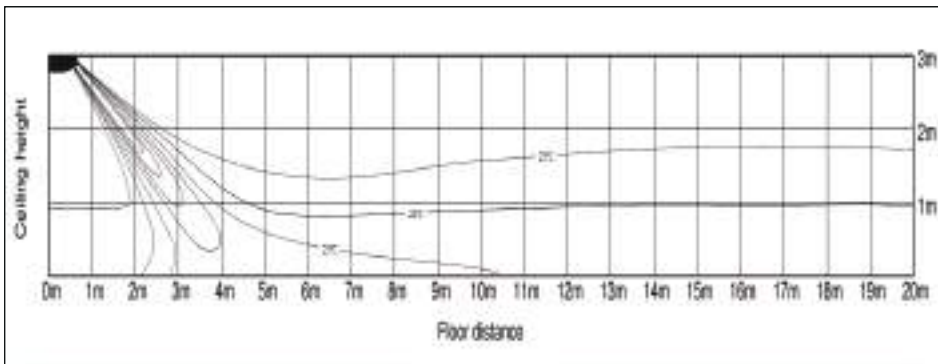

(3) Heating air velocity distribution

Discharge angle : 32°

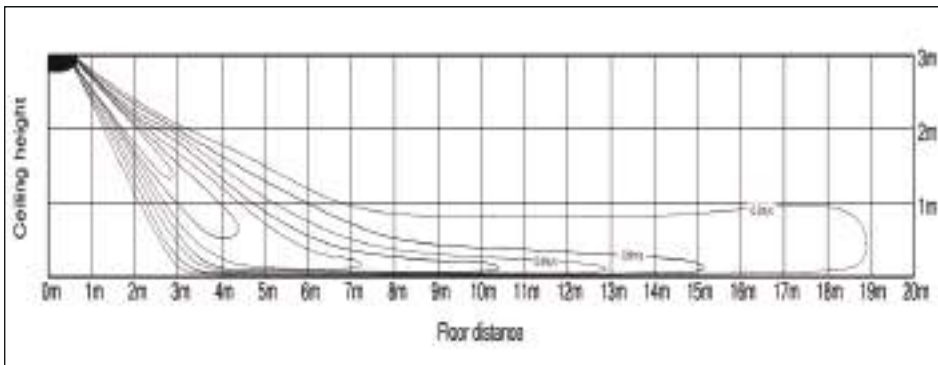

(4) Heating temperature distribution

Discharge angle : 32°

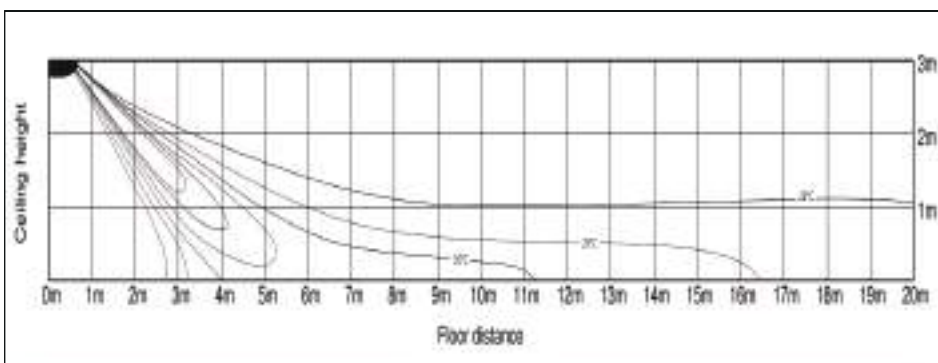

8 Cycle diagram

Outdoor

AC140JXADGH/AR, AC160JXADGH/AR

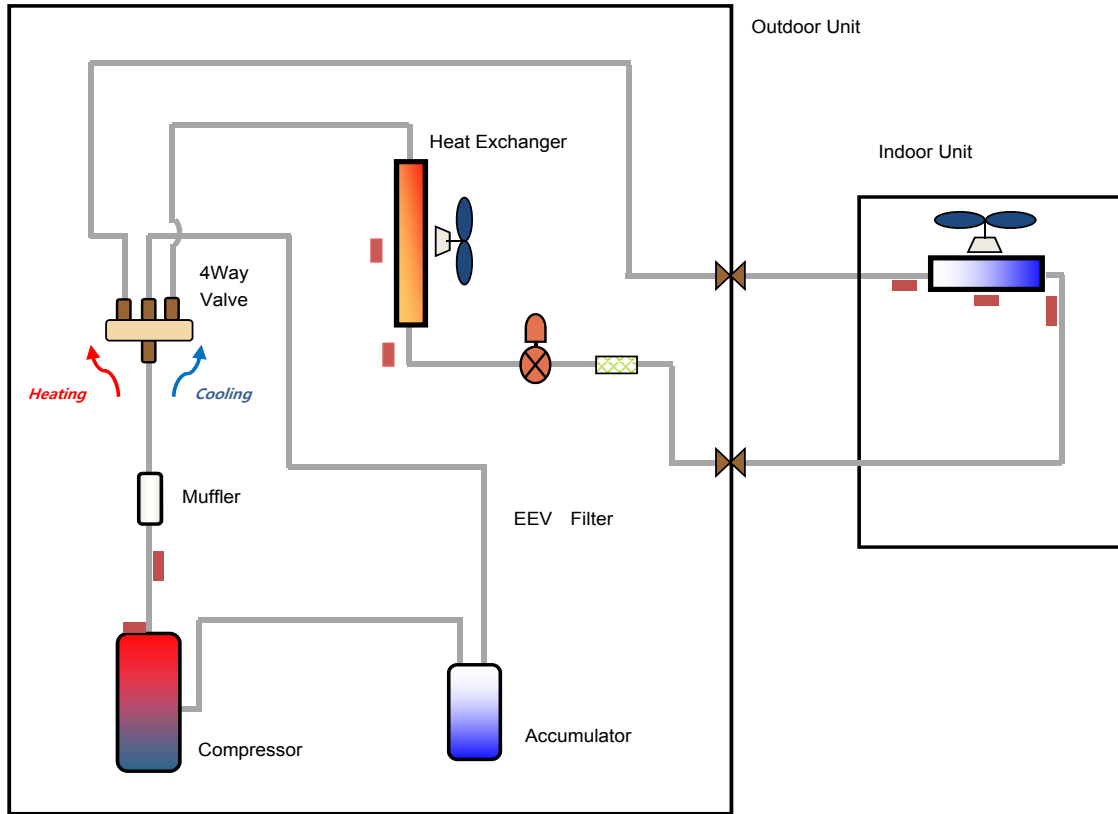

Category	Symbol	Description	
Compressor		Rotary Inverter Compressor	
Heat Exchanger		Condensing/Evaporating unit(FMC)	
Accumulator		Accumulator	
Filter		Filter	
Valve	Expansion		Electronic Expansion Valve(EEV)
	Reversing		4 Way valve (Reversing valve)
	Service		Service valve
Sensor	Temperature		Pipe/Air Temperature sensor

SAMSUNG

2017.02

Samsung Electronics Co., LTD.
B2B PM / SE

Head Office (Suwon Korea) 129, Samsung-Ro, Yeongtong-Gu, Suwon City, Gyeonggi-Do, Korea 443-742

Website : www.samsung.com Email : airconditioner@samsung.com

Images and data in this book may subject to change without prior notice.

SAMSUNG